

A COMPOSITE STRUCTURAL SYSTEM OF
STEEL-EDGED CONCRETE PANELS IN THE
INDUSTRIALIZED BUILDING CONSTRUCTION

by Kyong Soo Park

Bachelor of Architecture
Illinois Institute of Technology
May, 1981

Submitted to the Department of Architecture
in partial fulfillment of the requirements for
the degree of
Master of Science in Architecture Studies
at the
Massachusetts Institute of Technology
June, 1983

September 1983

© Kyong Soo Park, 1983

Signature of Author
Department of Architecture, June 7, 1983

Certified by
Waclaw P. Zalewski, Professor of Structures,
Thesis Supervisor

Accepted by
N. John Habraken, Chairman, Departmental
Committee on Graduate Students

MASSACHUSETTS INSTITUTE
OF TECHNOLOGY

FEB 25 1987

LIBRARIES

Rotch

A Composite Structural System of Steel-edged Concrete
Panels in the Industrialized Building Construction

by Kyong Soo Park

Submitted to the department of Architecture on June 7, 1983
in partial fulfillment of the requirements for the degree of
Master of Science in Architecture Studies

ABSTRACT

This thesis is to propose a structural system of steel-edged concrete panels, in the context of the industrialized building process.

Attempts were made to combine the merits of composite structural systems and the precast concrete panel system. The basic structural elements, panels for floor and wall, are conceived by breaking down the concrete encased steel structure for floor and shear wall into the panels, in a way that the steel sections are to dispose at edge of the panels. This steel-edge becomes the main characteristic of the system.

Design, manufacturing, and erection procedure are presented following the sequence of the industrialized building process, while they are simultaneously involved in generating the concept of the system.

A high-rise apartment building of cross bearing wall was chosen as a prototype for the presentation.

As this study is confined to suggest the configuration of one mixed steel-concrete structural system, detailed analyses are remained for further researches.

Thesis Supervisor: Wacław P. Zalewski
Title: Professor of Structures

TABLE OF CONTENTS

Title	1
Abstract	2
Introduction	4
Part 1. 1.1 Industrialization	6
1.2 Composite Structure	12
1.3 Precast Steel-edged Concrete Panel System	21
Part 2. 2.1 A Building Type	25
2.2 Components	26
2.3 Erection Procedure	29
Acknowledgements	38
Bibliography	39

INTRODUCTION

This thesis consists of two parts.

Part 1. Introduction of the precast steel-edged composite panel system.

Part 2. Description of the proposed system.

The proposed structural system of precast composite panels, as contained in the words, evolves in the overlap of two subjects: industrialization of building and composite structure. These two subjects are discussed first in general, and then followed by the introduction of the steel-edged concrete panel system itself concluding the Part 1.

In Part 2, the system is presented tracking the sequence of industrialized building process. A typical high-rise apartment building was chosen as a prototype, which is a cross bearing wall, double loaded corridor scheme which represents the lowest cost and most common type of apartment building built today.

Part 1.	1.1 Industrialization.....	6
	1.2 Composite Structure.....	12
	1.3 Precast Steel-edged concrete panel system.....	21

1.1 INDUSTRIALIZATION

Definition

Industrialization can be defined in many ways.

Carlo Testa proposed the one:

"Industrialization is a process which, by means of technological developments, organizational concepts and methods, and capital investment, tends to increase productivity and to upgrade performance."

Industrialized building, accordingly, refers to the application of building production technique modeled after those used by the major mass-production industries and characterized by the establishment of organized markets, large-scale prefabrication, and more direct involvement of building product manufacturers in the construction process.

And, Carlo Testa set forth four forms of industrialization currently used in the building trade:

- 1) Prefabrication
- 2) Modular system building
- 3) Rationalized building
- 4) Equipment-oriented site-production

These forms are not necessarily mutually exclusive but they can and do coexist on the same building project or within the same organization. These forms are more explored in the following section.

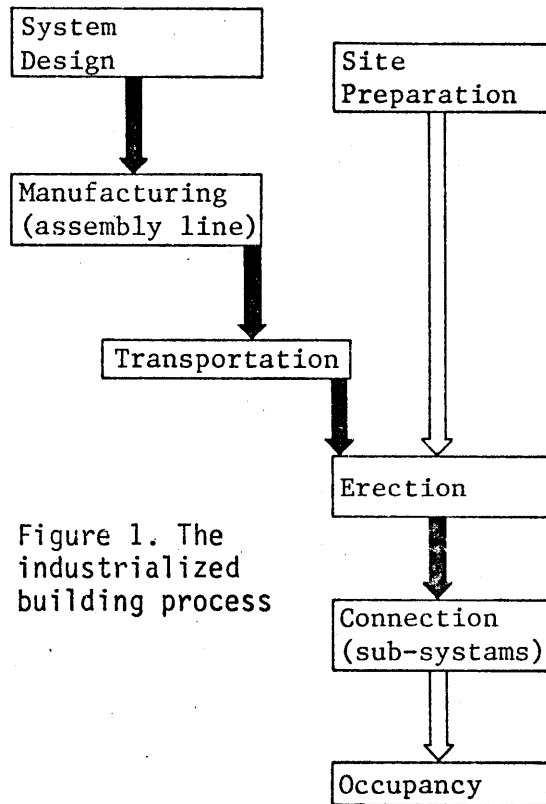

Figure 1. The industrialized building process

Nature of Industrialization

Industrialized building implies a new concept of rationalized architecture embodying a philosophy of planning and design, the use of advanced management techniques, organization of materials and manpower. It demands a far more complex and challenging form of management from the developer, the architect, and the contractor, than has been apparent before. It also involves continuity of construction, implying a steady flow of demand, standardization, and integration of the different stages of the whole production process.

In the operation of any system of industrialized building, all economical ways in which accuracy and control can be achieved must be employed, and specialized equipment and new techniques will evolve. Costly nonproductive works such as formwork, scaffolding, cleaning, and making good can and should be eliminated mostly by prefabrication of building components.

Prefabrication is a form of industrialization consists of producing parts which, when assembled, will give a finished product. It is first to design the finished product, then break down into meaningful parts from a production and assembly viewpoint, manufacture these parts, and assemble them in pre-scheduled sequence and order.

Modular system or dimensional coordination and control is a prerequisite of successful industrialization. The situation where every designer is free to choose a series of dimensions which differ only marginally from those chosen by other designers is undesirable and costly, because little difference in design means the difference between the standard and non-

standard element. It is according to the opposite conceptual process of prefabrication. One first design a set of dimensionally and functionally interrelated components, and establish general rules of how these components may be connected together and with these components then design a product.

Rationalized building is based on the attempt to increase productivity and performance by the application of advanced managerial techniques. In order to achieve an optimum use of men, machines, materials, time, and allocated costs, it is necessary to assess all the factors concerned with these five variables. As industrialized building is an overall conception of design, structure, and construction, integrated with production and the factor of demand, which must be mutually compatible, a production control organization can forecast and analyze and ensure that projects run smoothly from financing and design through manufacture and erection to occupancy.

In equipment-oriented site-production, the objective of increasing productivity is achieved by the utilization on the site, of highly sophisticated equipment which can, with little human intervention, produce complete buildings. This includes on-site factory system and equipment conveying system for linear operation. Also the inevitable problem of jointing is avoided to a considerable extent. Applying repetitive 'dry' connection detail, this form of industrialization can speed up the construction to the maximum. The characteristic at the base of the "systems approach" to building is the translation from craft to machine production, which generally entails pre-

fabrication in a centralized factory. Many advantages of factory and assembly line production tend to be the same for building as for the other product industries.

Advantages

i) Quality Control: High-precision machinery imposes a schedule and a discipline. Higher tolerances, more accurate measurements, with less maintenance and material waste and greater consistency of finish, result.

ii) Production Control: Programmed production, timed delivery and/or erection lessen the need for large stock inventoried left in the factory or on site. Construction is faster on the site where a more efficient order of building sequences can be maintained.

iii) Inventory Control: The tighter inventory controls possible in a factory setting, over small-piece building materials and components - piping, ducts, fans, windows, bricks, and tools - virtually eliminate the high rates of theft and vandalism on the site.

iv) Labor Control: More extensive use of unskilled labor is possible in the factory because of improved supervision (one foreman can adequately supervise more men) and because of the quality control inherent in the machinery.

'Wet' trades, in which labor is already in short supply, are eliminated as well as costly hours spent on skilled labor due to overlapping of plumbing, electrical, and finish carpentry trades.

A permanent site of employment guarantees full-time all-year jobs which

provide a more successful continuous employment relationship for both employee and employer.

v) Climate Control: Factory conditions release certain areas from the 'building season' limitations imposed by their climate conditions. A permanent labor force that can be employed when days lost to bad weather are minimized also reduces costs of training and initiation to jobs.

vi) Problem Control: The detailed appraisal of construction problems before work begins results in fewer delays in construction after commencement on the site.

Deterrents

Machine production, however, requires large capital investments at preconstruction stages for tooling, factory installation, and transport (for central factory systems) and/or factory relocation (for on-site factory systems). At the present time, clear financing mechanisms for preconstruction investment do not exist for the building industry as they do for the automotive industry. In any case, these investments would have to be justified by large guaranteed markets in the form of large single projects (for on-site factories), coordinated smaller projects within economical transport distances (for heavy-component central factories), or modular coordination for many small open-system projects on a nationwide scale (for light-component central factories). This guaranteed market must then be sustained over a long enough period of time to amortize these expenditures before profits can be calculated. Fragmented and localized subcontracting practices,

administrative (code) and labor union policies, and professional attitudes still hinder the development of large markets on a localwide or nationwide scale.

In order to achieve the successful industrialization of building, the work and organization required of the architect's design team and the contractor's management and erection teams require a new philosophy allowing for full cooperation at an early design stage. The manufacturer, by the same token, has today to absorb this new attitude and supply factory-finished sub-assemblies which are larger and more complex than previously done on-site. In addition, the packaging and supplying of components is according to a more specific and rigorous schedule.

The new philosophy - a thinking awareness of the real meaning of industrialized building and the implications of its use - together with an understanding of what each member of the building team is trying to achieve, can result in more flexibility for negotiation, cost planning, and other techniques which are beneficial to client, architect, contractor, manufacturer, and user.

1.2 COMPOSITE STRUCTURE

The term 'composite structure' in building construction can refer to structural systems in which there is interaction between such diverse materials as steel and concrete in reinforced concrete, steel and timber in a flitched beam, glass fibres in a resin matrix, or brick infill panels in a steel frame.

In this thesis the term is used only to refer to the interacting behavior of concrete with structural steel. This can take the form of isolated composite members, such as beams, slabs and walls, or mixed steel-concrete systems and subsystems involving the interaction of an assembly of members composing the system. The former is a study of the behavior of components of a system, whereas the latter involves the entire system

There appears to be a recent trend to use mixed steel-concrete systems on a much broader scope, including the formation of a wide variety of steel-concrete interacting subsystems and total systems. This trend in the mixed form can be associated with the "system design" approach which has evolved a considerable number of systems in steel and concrete high-rise building systems in the last decade. There is an increased flexibility among designers to consider different combinations in the mixed steel-concrete form, which has led to an awareness that optimum and useful building solutions are often obtained by considering the full potential of two materials working integrally.

The history of application of composite designs dates back about forty years, particularly for member designs. Formalized design standards and specifications for composite members have evolved at a slower pace compared to that of structural steel and reinforced concrete, because the design standards for composite members have evolved from either steel or concrete design methods. Composite column designs are covered in the ACI Code and composite beam designs in the AISC Code. Design standards are not currently available for other elements, such as slabs, walls, panels, etc.

While various forms of composite structure are used in building practice, only a few typical cases are reviewed in this part, which are:

- 1) Composite Columns; Concrete encased steel columns, and
Concrete filled tubular columns
- 2) Composite Beams and Slabs
- 3) Mixed steel-concrete Systems

Concrete encased steel columns

Historically, the concrete encasement of structural steel shapes was intended as fire protection for columns and beams. Even though it was generally recognized that such encasement would increase the strength and stiffness of a steel column, the strength contribution of the concrete encasement was largely ignored until the late 40's. In fact, in these earlier designs, the steel column itself was designed also for the additional weight of concrete. Most recently in the last decade, some designs have included the additional column stiffness for frame behavior under

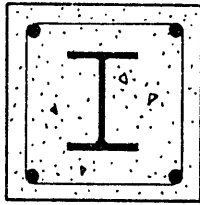

Column with Small Steel Core

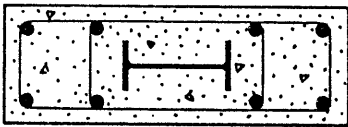

Deep Reinforced Column

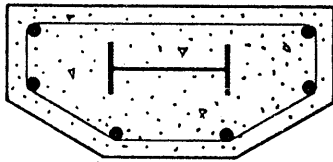

Molded Shape for Exterior Column

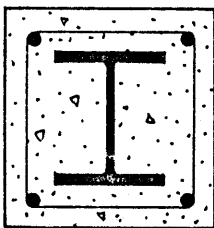

Large Steel Core in Concrete

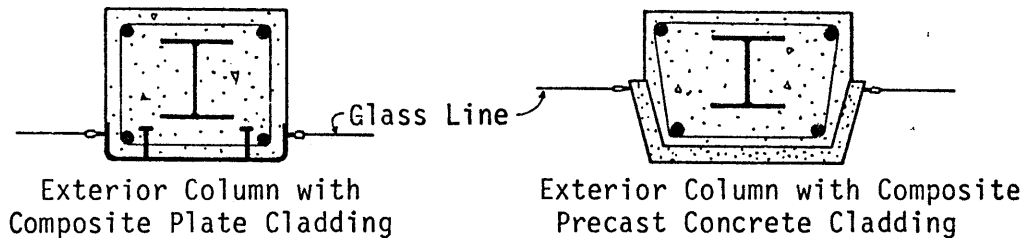

Exterior Column with Composite Plate Cladding

Exterior Column with Composite Precast Concrete Cladding

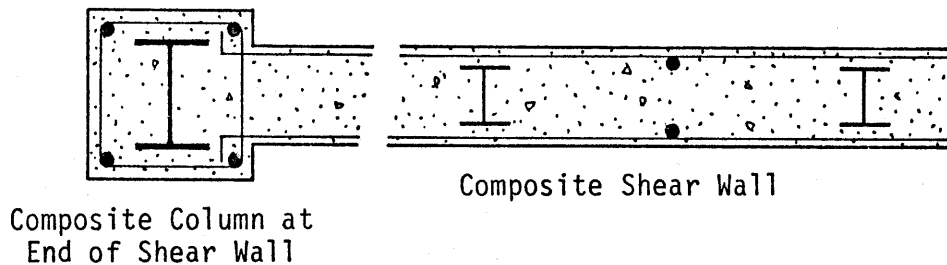

Composite Column at End of Shear Wall

Composite Shear Wall

lateral load while ignoring the strength increase. The ability of the concrete to carry its own weight and in some cases, some additional stress, has also been considered in some recent designs.

As construction labor cost increased rapidly after W.W.II and onward, concrete encasement for the fire protection purpose alone has been replaced by the sprayed-on contact fire protection method, so the form work has also been eliminated. Yet, the current and future use of encased steel columns has to be justifiable on its own merit as an economical structural column comparable with steel columns with other forms of fire protection.

Some examples of encased columns are shown in Fig.2.

Figure 2. Composite Column Forms

Concrete filled tubular columns

It has been recognized by engineers for some time that there are advantages to be gained by filling hollow circular or rectangular steel tubes with concrete. The advantages can be itemized as below:

- 1) The column load capacity is increased by the fact that the concrete core in addition to its own strength contribution, also helps to prevent local buckling of the steel tube.
- 2) Since the tubes themselves constitute the formwork, the increased capacity of column is obtained at no extra formwork cost.
- 3) There is evidence of increased fire resistance due to concrete filling which requires thinner application of additional fire protection for most cases, or eliminates all together.
- 4) From an architectural point of view, tubular columns with or without concrete filling have the advantage of slender and thinner columns compared to conventional columns.
- 5) Simple, non-continuous beam-to-column connection either by shear plate or a bearing cap plate are generally used.

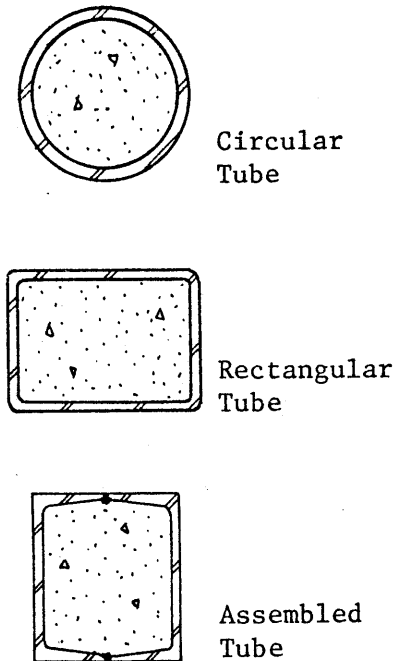

Figure 3. Concrete filled tubular columns

The limitations of this column are as follows:

- 1) Variety in sizes of columns are limited by the available sizes of tubing, unless tubes are composed of several separate parts.
- 2) Continuous moment connections are considerably more complicated with tubular columns, which renders their use prohibitive for multi-story rigid frames.

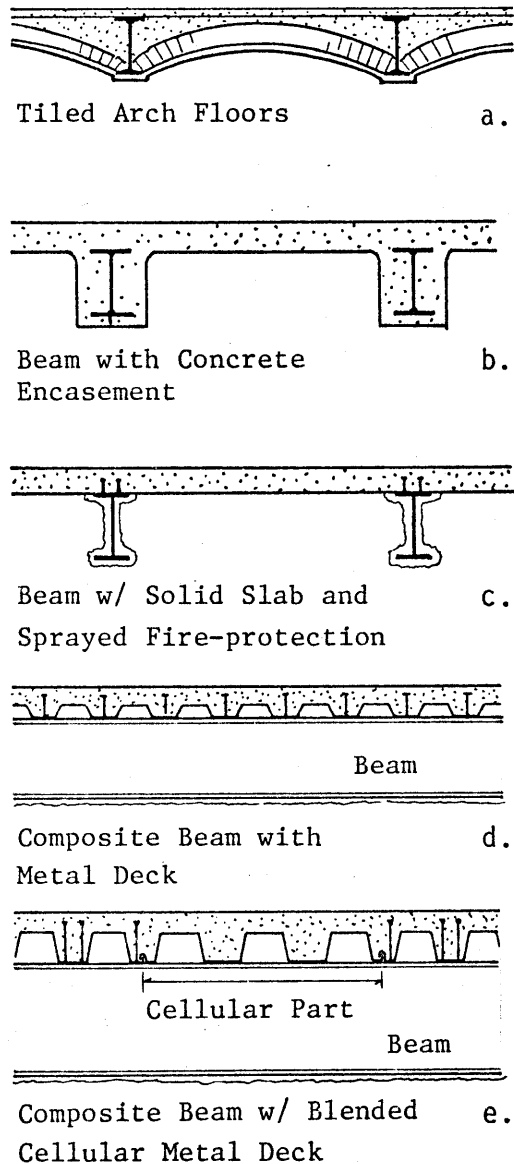

Figure 4. Type of Composite Beams

Composite beams and slabs

Development of composite beam systems in building is closely related to the development of floor systems themselves. Before the turn of the century, steel beams were used at spacings of 4 to 6 feet, which were spanned by tiled arches (Fig.4 a). Flat floors were then obtained by filling above the arches and steel beams with concrete. This form of floor system was later replaced by a solid concrete slab and steel beam system (Fig.4 b) encasing the steel beam with concrete to provide fire protection. In most initial applications, these beams were designed to resist all loads ignoring the composite action, provided for large reserve load capacities. In later applications, the composite beam took the form of a solid concrete slab on beams (Fig. 4 c) with sprayed-on fire protection for beams.

Considerable advances had been made in the cold formed metal deck systems through the 50's to a point where they were used typically as the slab element including a concrete fill on top (Fig. 4 d).

Often the metal deck was in a cellular form where the cells were used to provide for power lines on a modular basis (Fig. 4 e).

The obvious advantage of the metal deck slab system was in the elimination of formwork and shoring, providing working platform, and the consequent increase in speed of construction. A composite slab system has now developed where the metal deck acts compositely with the floor concrete, as the metal deck providing for tension capacity as in reinforced concrete slabs. Through 70's, the composite slabs involving a metal deck have also been used for composite design of

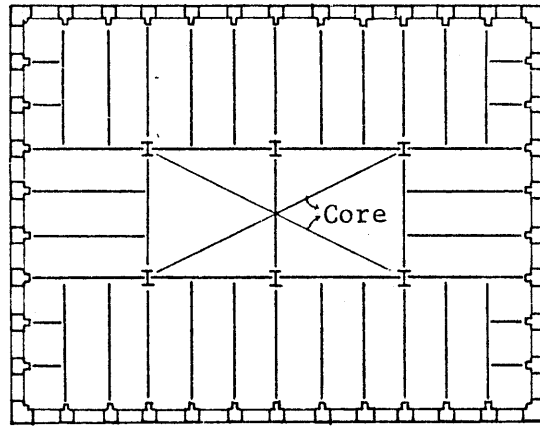

Typical Floor Plan

beams. The ability to weld shear connectors through the metal deck reliably has been primarily responsible for this. Typically, this slab system is used for a slab span range of 6 to 9 feet, generally with an 1½ inch deck. There has been a recent trend, however, to increase the slab span range to 15 feet, which requires deeper deck up to 3 inches beyond a 9 ft. span.

Mixed steel-concrete systems

These systems refer to entire building systems rather than members. As all steel buildings involve concrete in some form and most concrete building involve steel reinforcing, in a sense, most buildings are of mixed steel-concrete systems. Here, it is designated to involve composite behavior of steel and concrete elements in the same building. These systems consequently are combination buildings borrowing components from structural steel or concrete building systems. Many combinations have been evolved over a decade or so and involve particular identifiable types of systems. They include composite tubular system, concrete core braced system, and systems involving composite claddings. These are briefly discussed with figures.

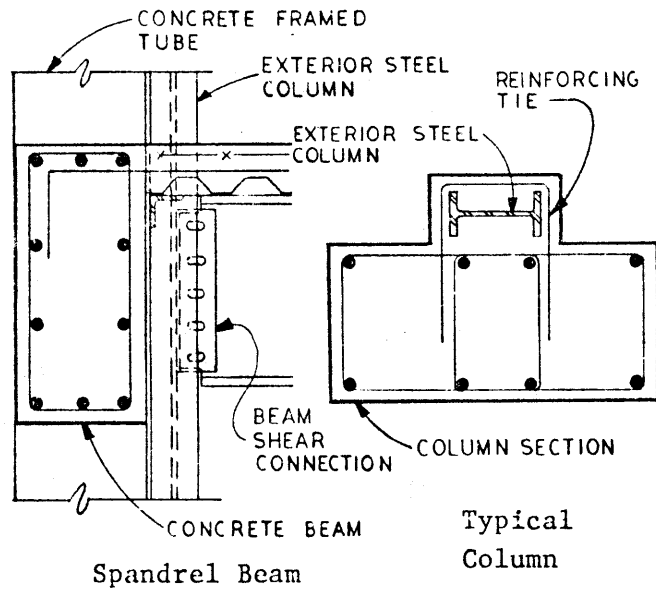

Figure 5. Composite Framed Tube System

Composite tubular system is generally applied to a high-rise building structural system which combines the essential properties of an exterior equivalent framed-tube system in reinforced concrete with simple structural steel framing on the interior. In principle, the equivalent tubular component resists all lateral loads of

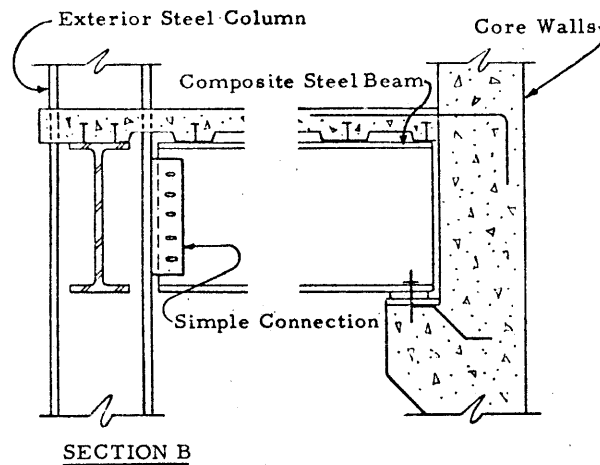
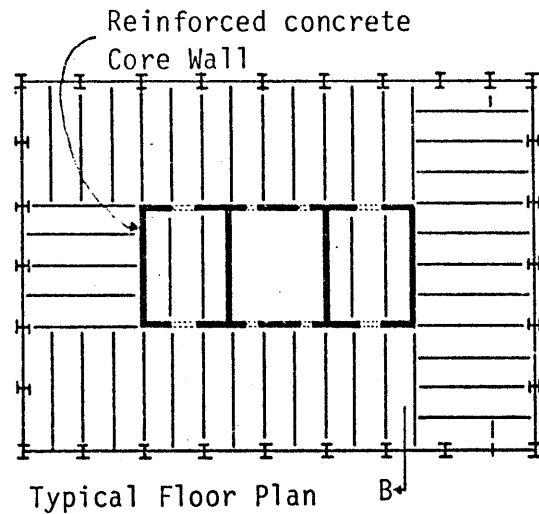

Figure 6. Central Core Braced System

wind or earthquake in terms of both stiffness and strength, whereas the structural steel component is required to carry only its share of the gravity loads. This concept is shown in Fig.5 which indicates the concrete framed-tube envelope on the periphery and steel floor framing and columns on the interior. This combination of structural steel and reinforced concrete subsystems has used resulting in efficient and economical solution.

Core braced systems represent a class of high-rise structural systems where the predominant lateral load resistance is derived from bracing provided around building core element. The bracing take the form of interconnected concrete shear walls with interior cross walls enclosing the core. The basic behavior of this element under lateral load is that of an equivalent cantilever.

The building core generally involves centralization of various building service elements such as elevators, fire stairs, mechanical-electrical shafts, toilets, etc. The planning of structural elements in and around the core is, therefore, closely related to the disposition of these core elements. Considerable variations in core layouts can exist depending on the occupancy of the building and the overall building volume.

Composite cladding: The contribution of architectural facade materials to strength and stiffness of the building has traditionally been ignored. It is well known that early high-rise buildings with masonry claddings are extremely stiff in terms of lateral sway and that a

Figure 7. Composite Claddings

substantial portion of this stiffness was actually derived from these masonry infills. Even though masonry facades for modern high-rise buildings are rather uncommon, considerable potential exist for evolving facade design with modern materials and methods, whereby the beneficial effect of the composite behavior can be utilized to reduce the quantities of basic structural materials. Brief descriptions of some examples are shown in Fig.7.

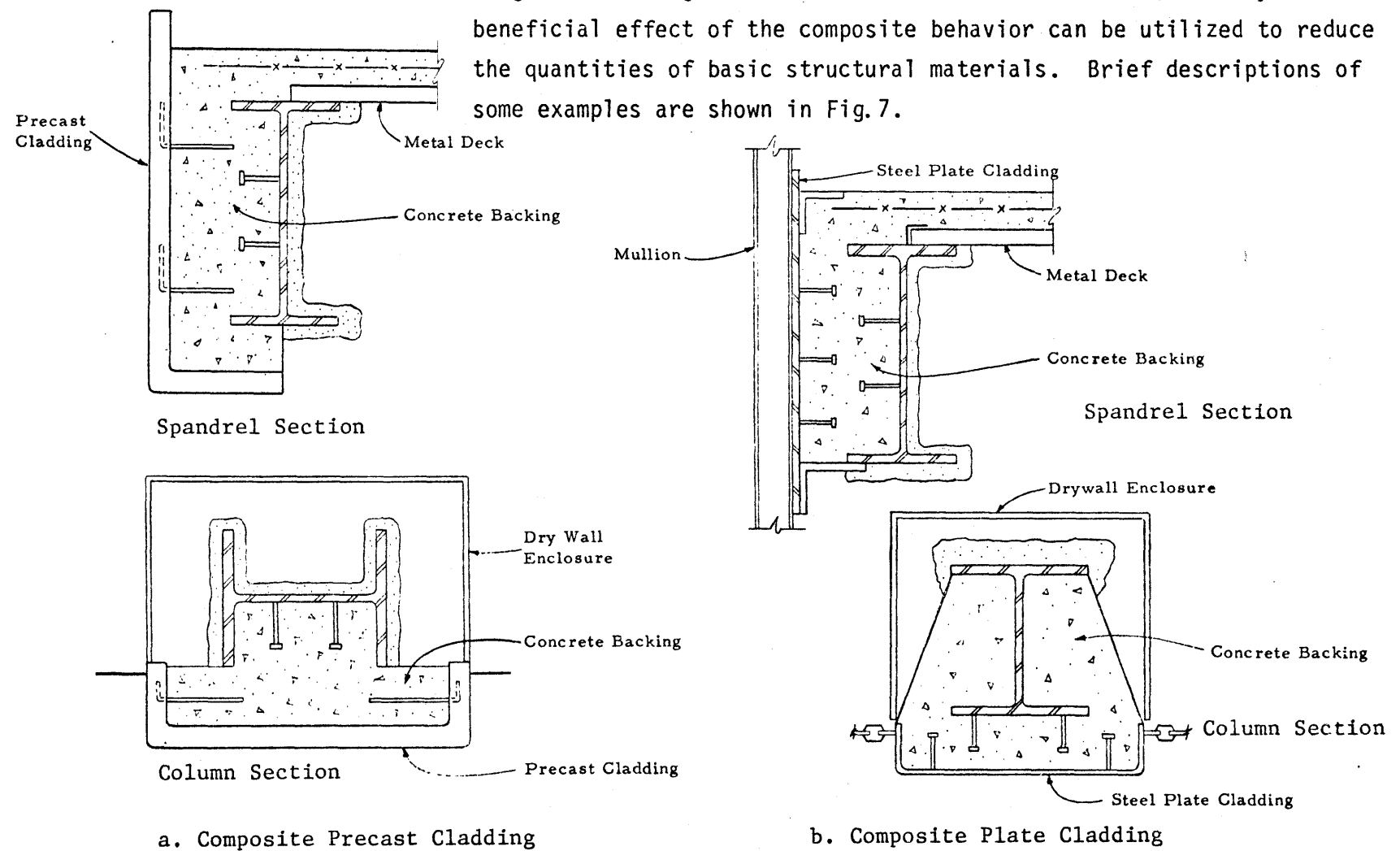

a. Composite Precast Cladding

b. Composite Plate Cladding

Advantages and Disadvantages of Composite structure

The basic advantages resulting from composite design are

- 1) Reduction in the weight of steel
- 2) Shallower steel beams
- 3) Increased floor stiffness
- 4) Increased span length for a given member
- 5) Increased overload capacity

A weight savings in steel of 20 to 30% is often possible by taking full advantages of a composite system. Such a weight reduction in the supporting steel beams usually permits the use of a shallower as well as a lighter member. This advantage may reduce the height of a multistoried building significantly so as to provide savings in other building materials such as exterior walls, stairways, and various vertical elements.

The stiffness of a composite floor is substantially greater than that of a concrete floor with its supporting beams acting independently. The increased stiffness considerably reduces the live-load deflections. Assuming full composite action, the ultimate strength of the section greatly exceeds the sum of the strengths of the slab and the beam considered separately, providing high overload and longer span capacity.

The overall economy of using composite construction when considering total building costs appears to be good and is steadily improving.

Some disadvantages are listed as below:

- 1) The cost of the connectors which offsets savings in beam materials.
- 2) In the case of continuous beams, the advantages of composite action is reduced in the area of negative bending moment yields.
- 3) Long-term deflections might be important when the composite section is a substantial portion of the dead loads or if the live loads are of a long duration.

1.3 PRECAST STEEL-EDGED CONCRETE PANEL SYSTEM

The abstract of this proposed system has been generated from the attempts to combine merits of composite structure and industrialized building process.

The steel-edged concrete panels are conceived blending prefabricated panel system and concrete encased steel floor and shear wall system. As illustrated in Fig.8, basic panel elements are obtained by taking segments of the composite floor or wall structure, in a way that the steel sections are to dispose at edge of the panels, which becomes the main characteristic of this system.

The steel-edge contributes to the whole system as following:

- 1) The steel section composes a part of the formwork at the prefabrication stage, that stays on edge of the panel later yielding composite structural behavior.
- 2) Placing steel sections at edge allows the control over higher tolerances, more accurate measurements, and greater consistency of finish.
- 3) As the steel section protect the concrete panels from chips and cracks which would damage the panels considerably and require restoring job on site, it will ease and consequently save the cost of handling and transportation of components.
- 4) Since the connection of the panels takes place mostly in between

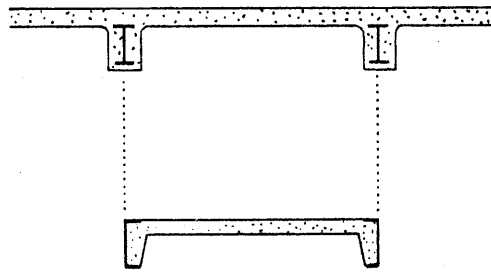

Floor Panel

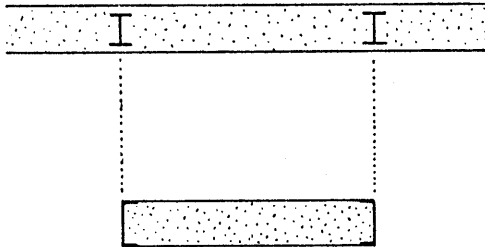

Wall Panel

Figure 8. Steel-edged Panels derived from composite structures

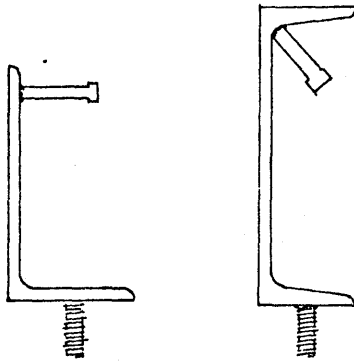

Figure 9. Steel Sections

steel sections, relatively simple 'dry' connection - bolting or welding - can be used repetitively, and more importantly, it will require only one type of crew, i.e. steel, on site assembly, which simplifies and so shortens the construction procedure by minimizing the conflicts between crews of different trades.

At prefabrication stage, the steel sections are treated first for the future connection with the highest level of control. For the floor panels, channel or angle shapes structural steel can be used for the steel section, while a cold formed section in channel-like shape is for the wall panels.

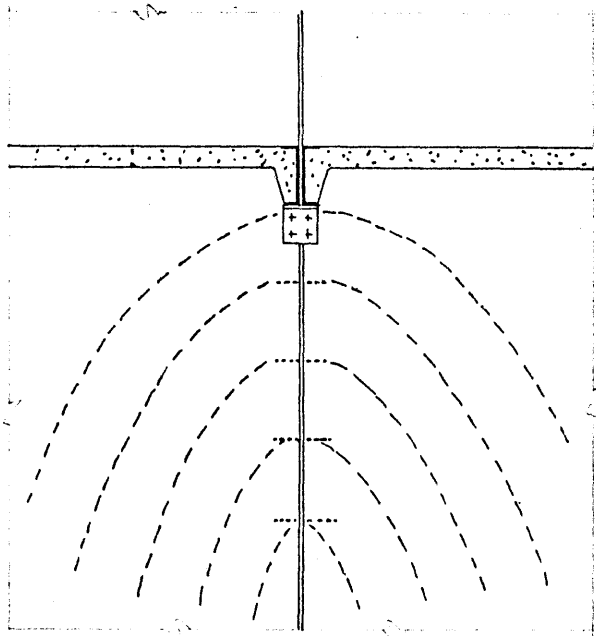

Figure 10. Force diaphragm in wall panel

When these panels are assembled, the total structure is to refer to the original composite structure from which the panels are derived. The edge of wall panels take the load carried by the edge of floor panels which act like composite beams. Then this load is transferred into concrete walls by the shear connectors welded inside of the steel sections at regular intervals and embedded in concrete, developing the force diaphragm as shown in Figure 10. Forces in one wall panel also can be transferred to the adjacent wall panels that gives more value to resist the lateral load.

With multi-story height wall panels, floor panels are connected to the side of wall panels by angle shape connectors which is attached to the walls by high strength bolts penetrating wall panels. This invites the simple connection which eliminates negative moment area

that reduces the benefits of composite structures.

In a cross wall system, the walls perpendicular to the floor supporting bearing walls such as walls for corridor, staircase, and cladding provide lateral resistance in the longitudinal direction.

Part 2.	2.1 A Building Type.....	25
	2.2 Components.....	26
	2.3 Erection Procedure.....	29

2.1 A BUILDING TYPE

A typical high-rise apartment building was chosen as a prototype, which of cross bearing wall, double loaded corridor scheme.

Units include 1,2, and 3 bedrooms on each floor. Along the both sides of the corridor, spaces of 1 ft. gap between floor panels are reserved for the service walls.

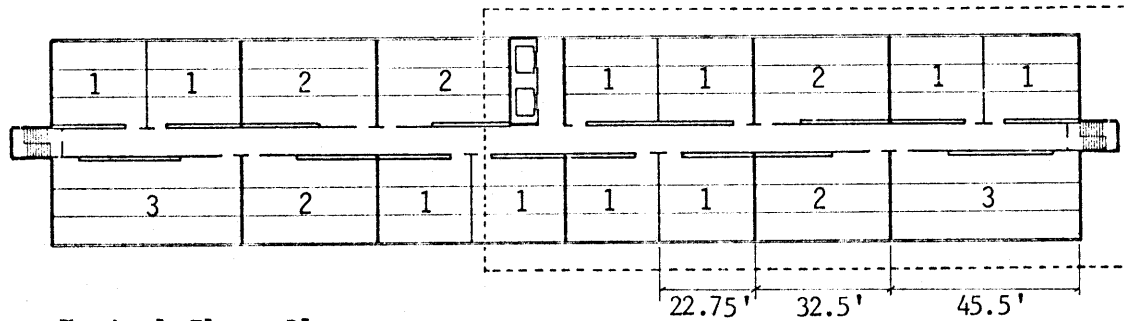

Typical Floor Plan

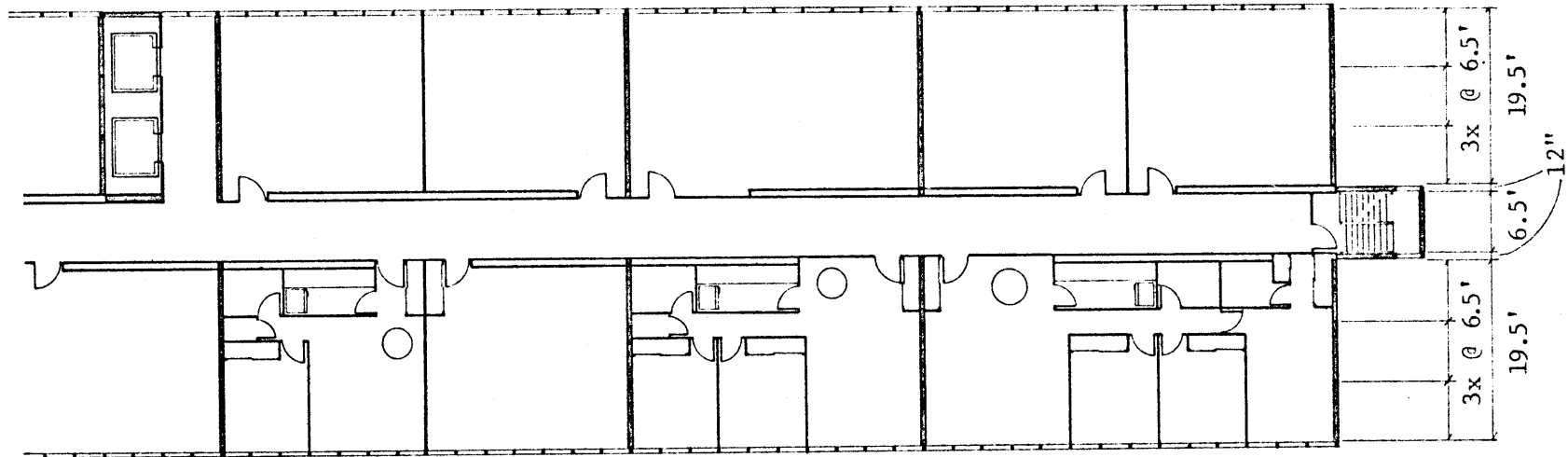

2.2 COMPONENTS

Building components consist of

- 1) Floor Panel
- 2) Wall Panel
- 3) Tubular Column
- 4) Connectors

Floor Panel

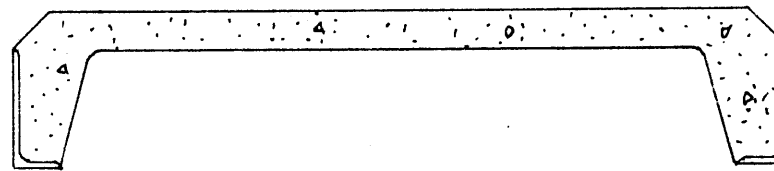
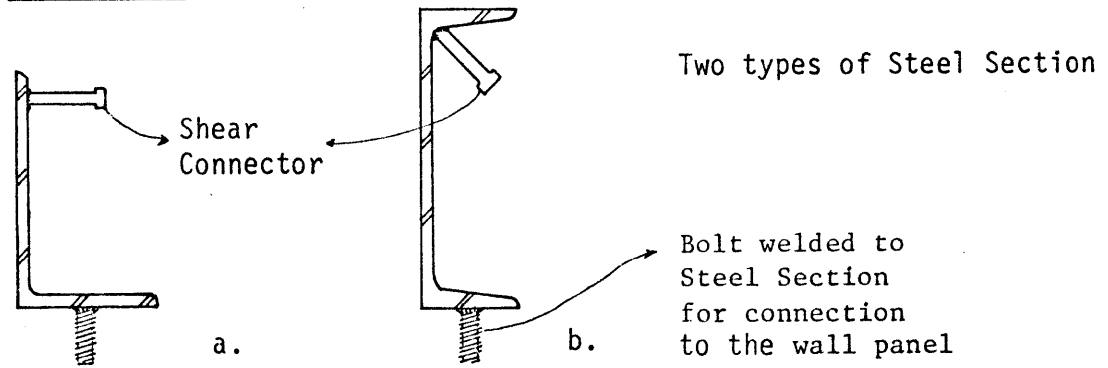

Section through Floor Panel type a.

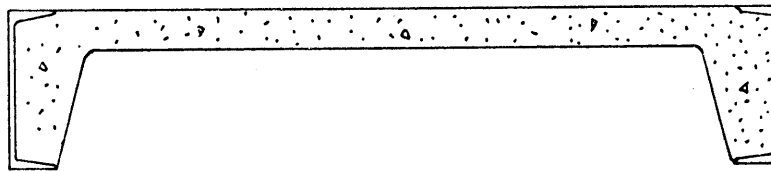

Section through Floor Panel type b.

Wall Panel

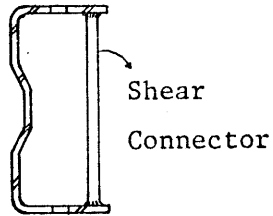

Cold Formed Steel Section

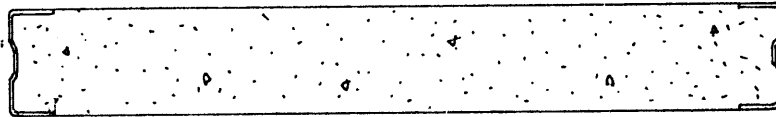
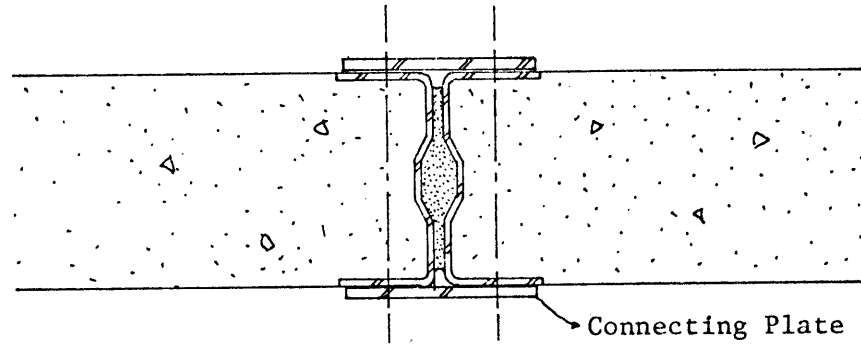

Tubular Column

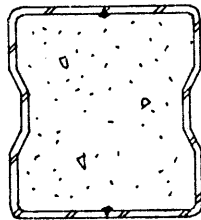

Welded Tube of two steel sections from wall panel

Connectors

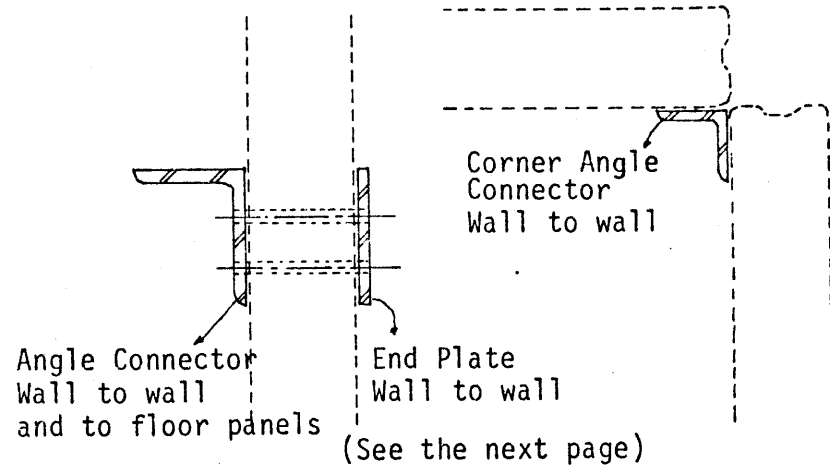

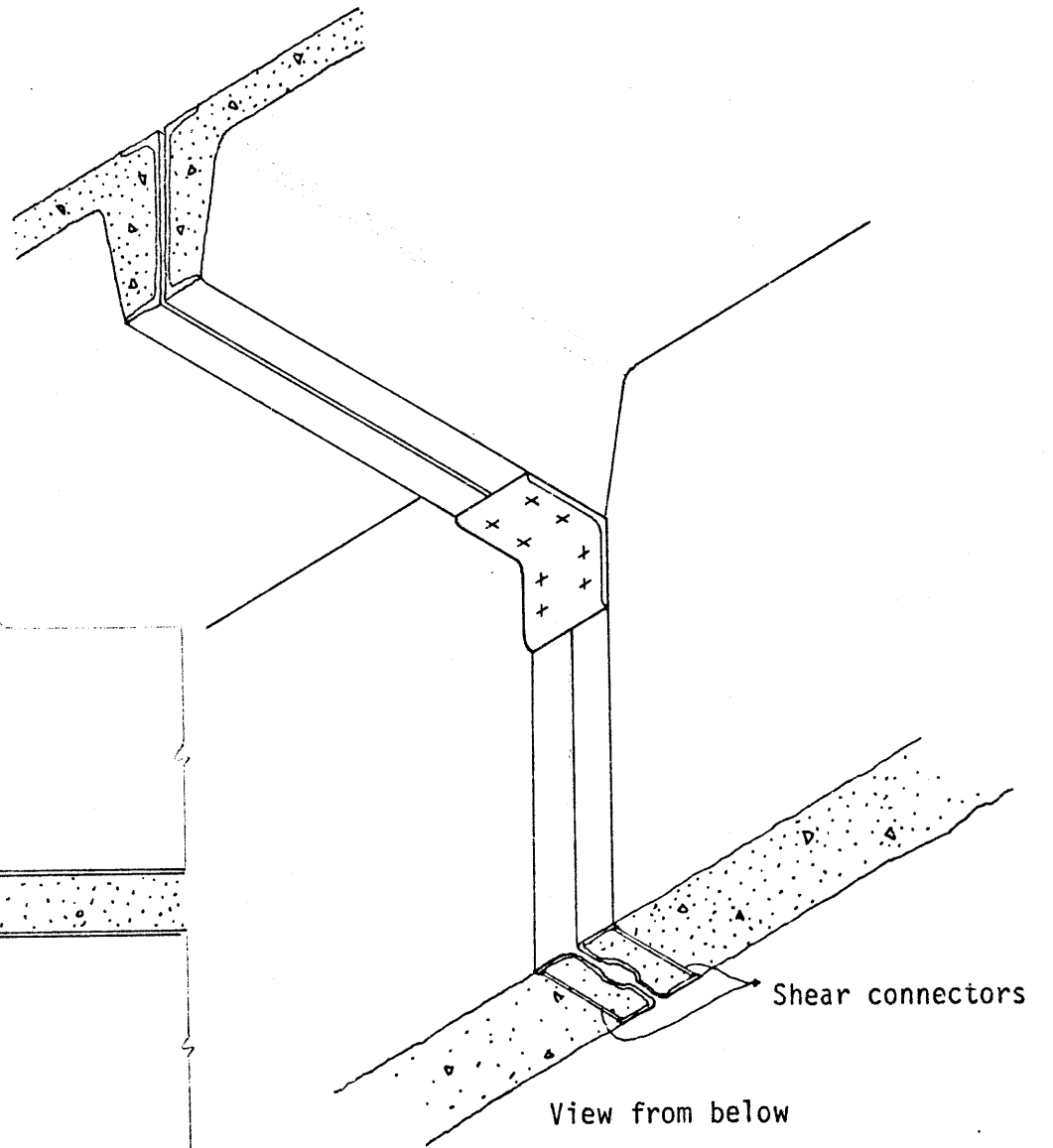
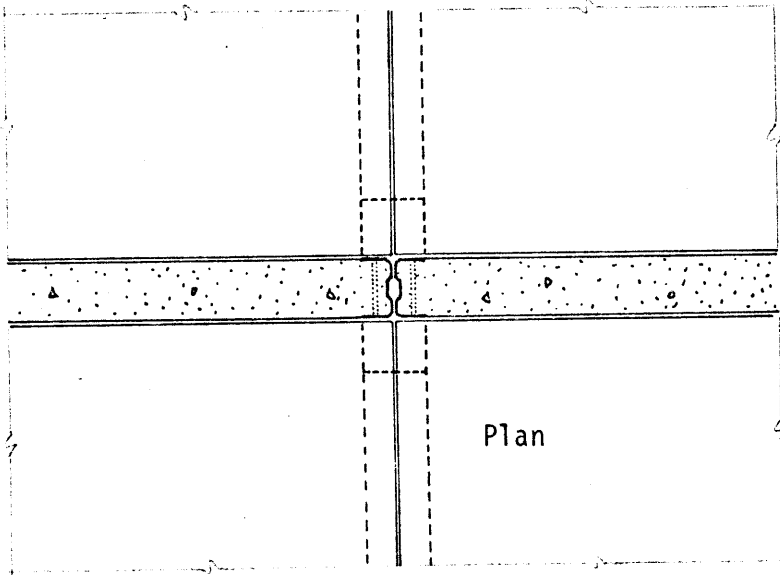
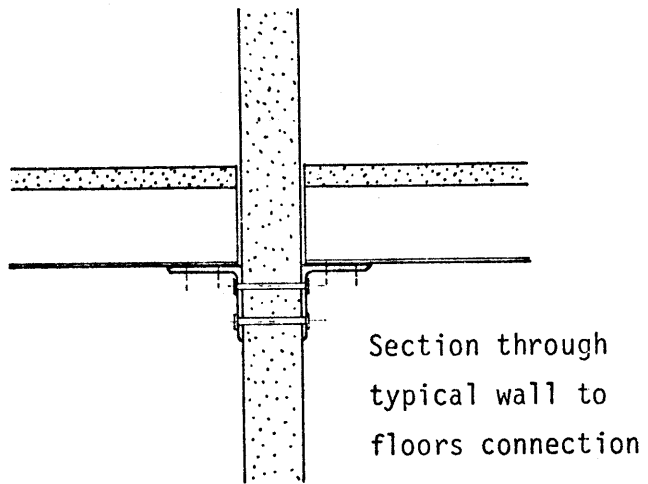

2.3 ERECTION PROCEDURE

The erection procedure from placing footings to the end of the first cycle for super-structure, up to the fifth floor, is presented in following pages.

- Stage i) After earth excavation and leveling, stripe footings are placed along the bottom of the bearing walls and foundation walls. Utility lines are also drawn into the building site and installed along the longitudinal axis of the building before the footings are set up.

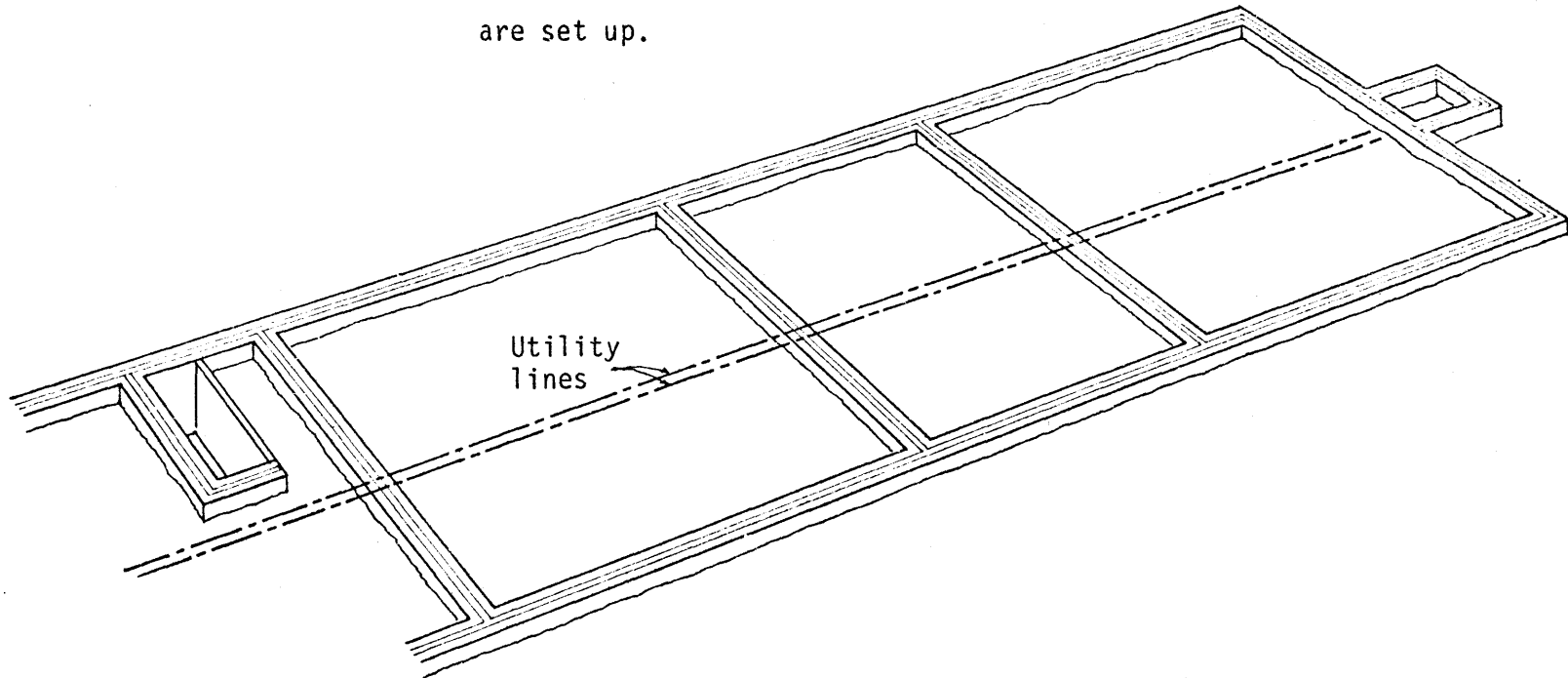

Stage ii) Foundation walls and part of bearing walls for an elevator shaft and staircases.

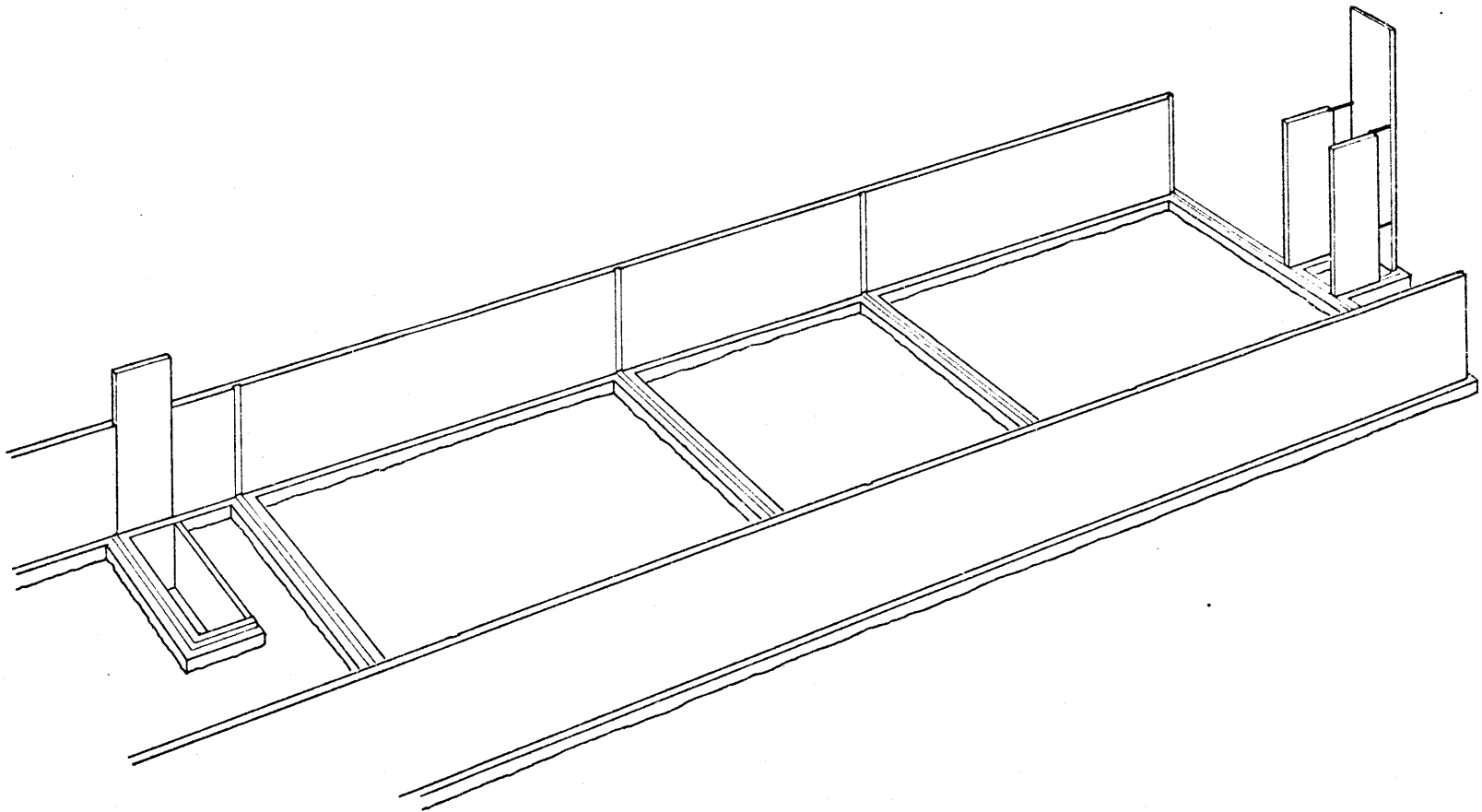

Stage iii) Bottom part of the bearing walls are set up on the footings and connected each other. Basement floor slabs are either poured on site or placed by precast concrete panels. Two lengths of the bearing walls, 1.5 and 2.5 floor height, are arranged in staggered form.

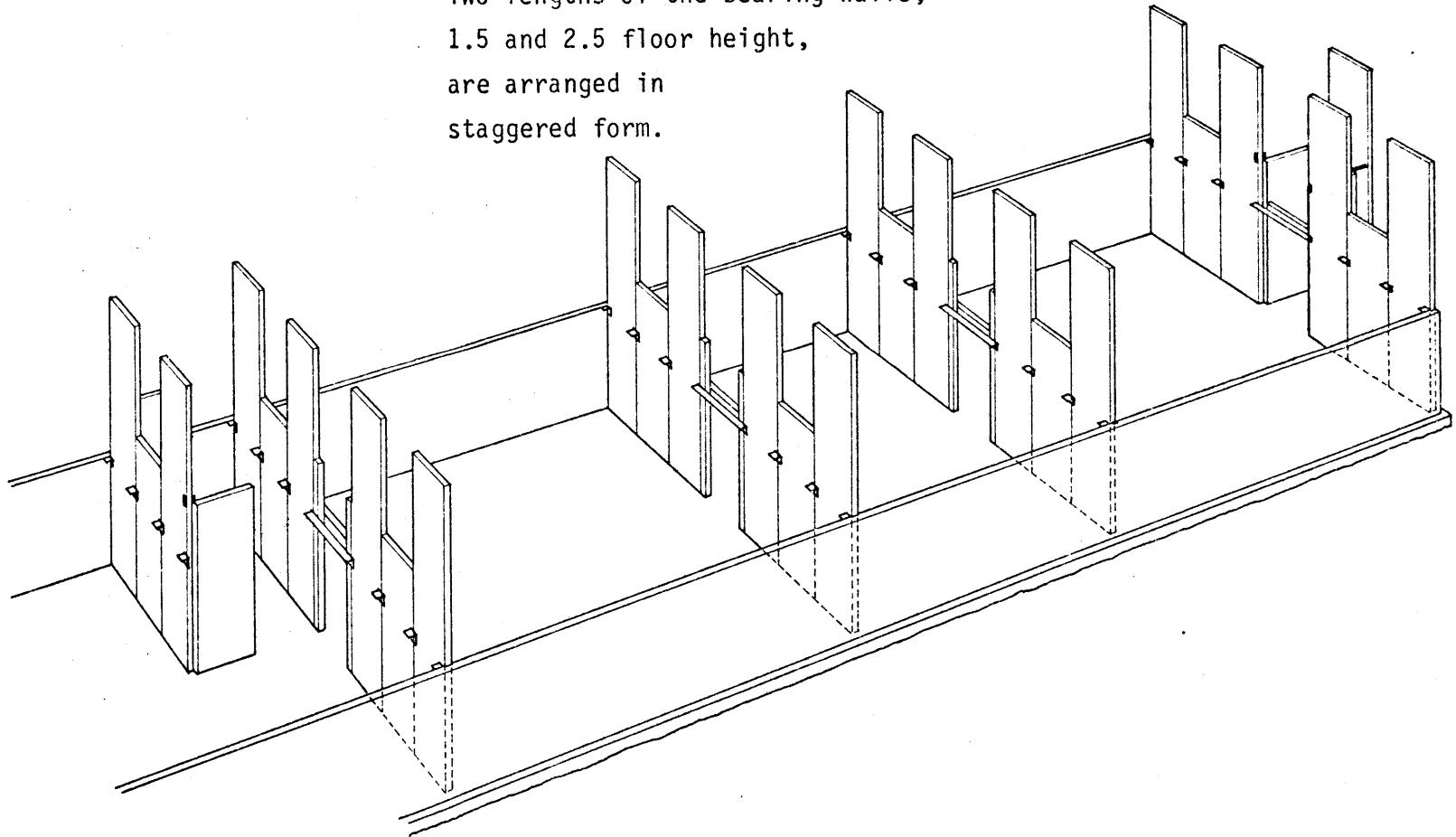

Stage 1) This is the first stage of the first cycle for super-structure erection procedure, Floor panels for the first floor are placed. An elevator shaft and stairways are erected first, which are not included in the cycle for super-structure.

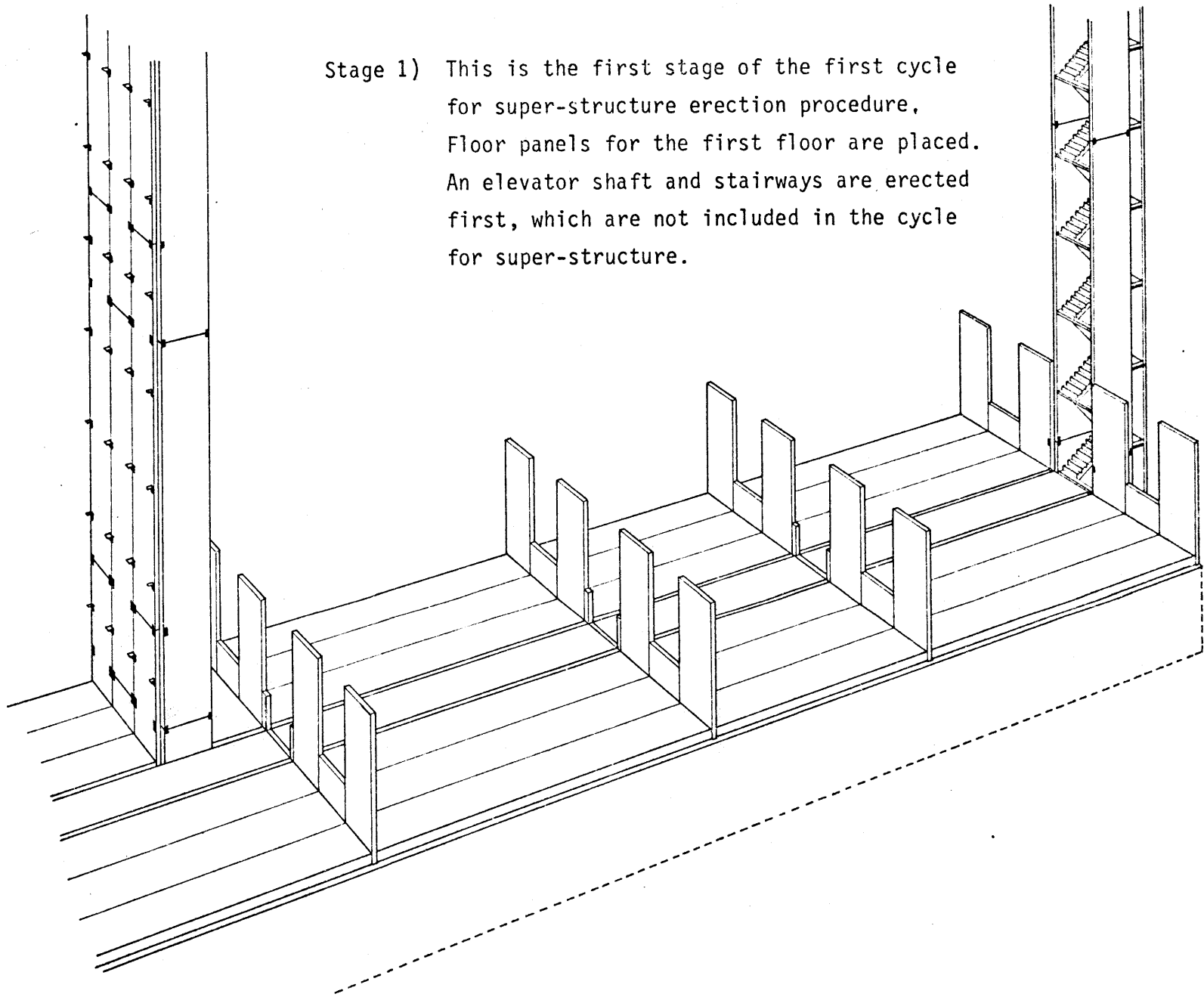

Stage 2) Typical bearing wall panels of 4 fl. height are slipped in and connected.

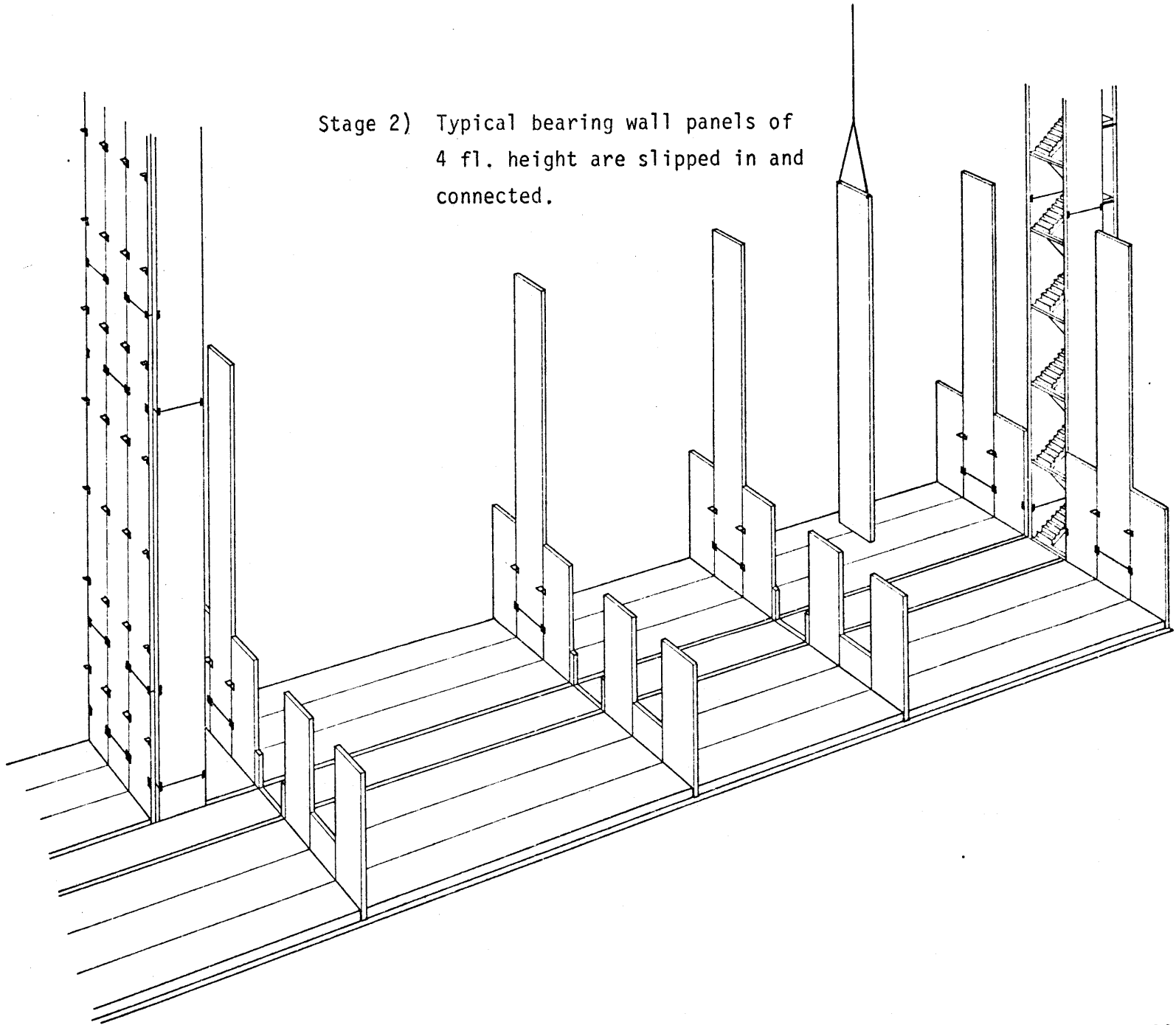

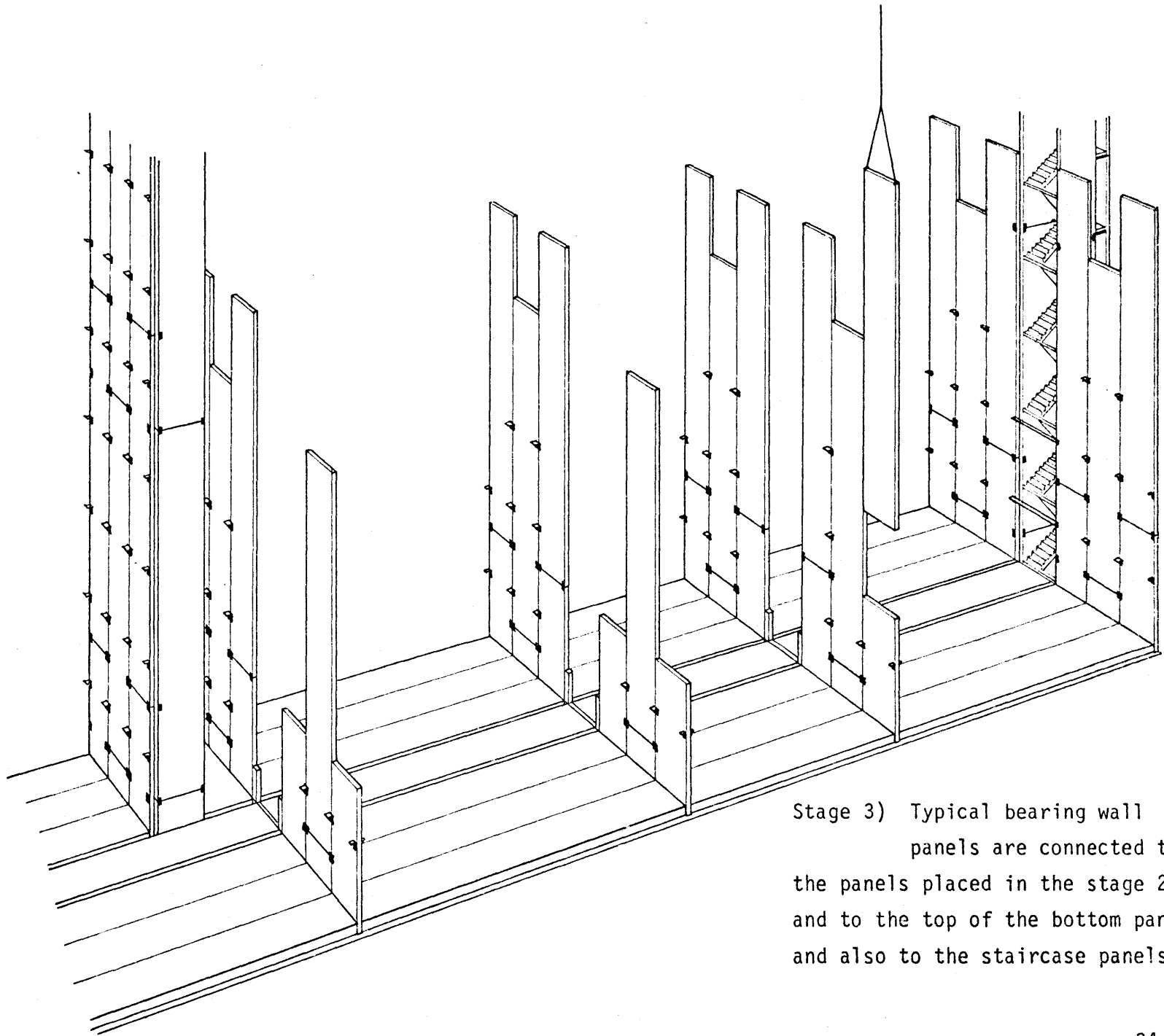

Stage 3) Typical bearing wall panels are connected to the panels placed in the stage 2) and to the top of the bottom panels, and also to the staircase panels.

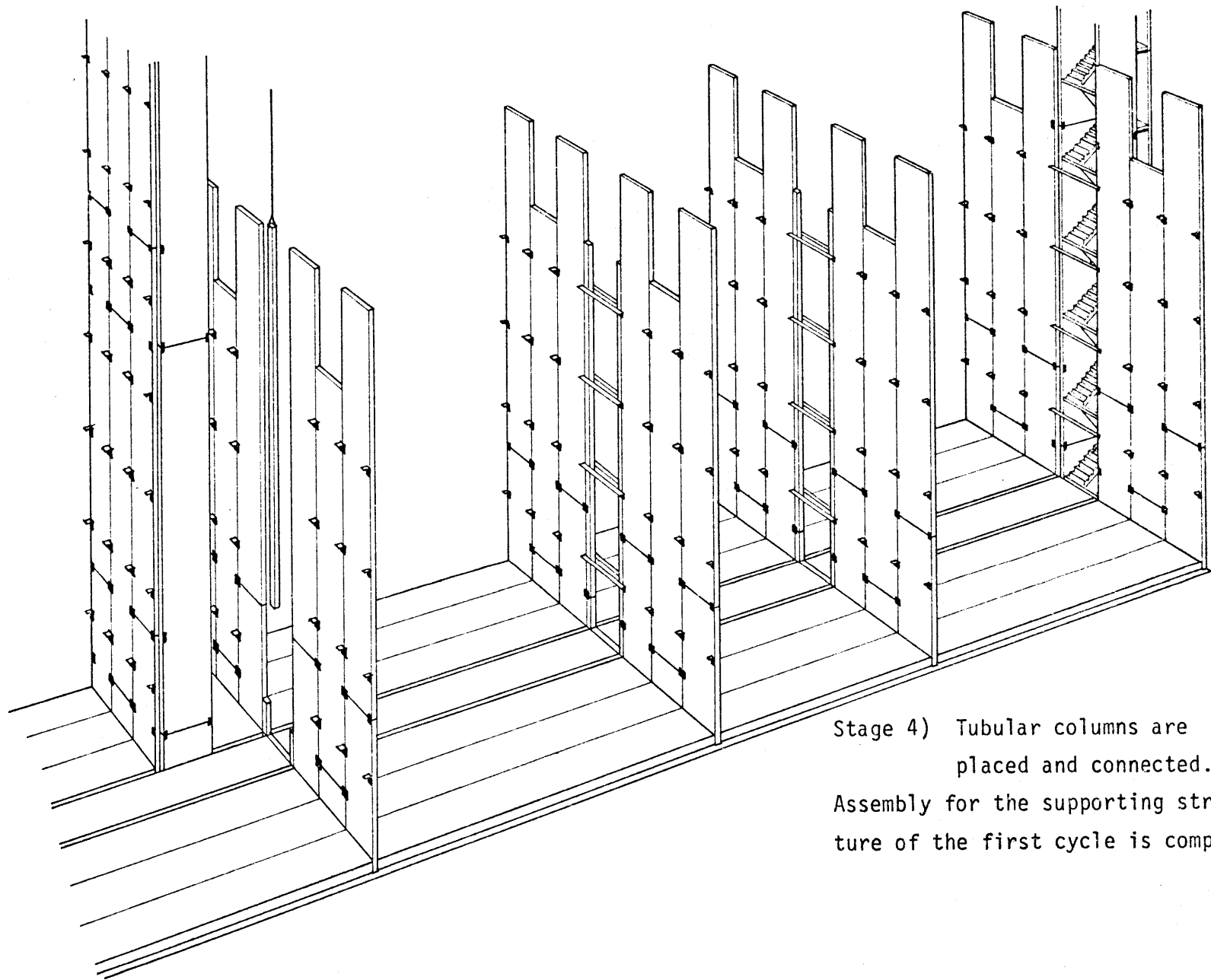

Stage 4) Tubular columns are placed and connected. Assembly for the supporting structure of the first cycle is completed.

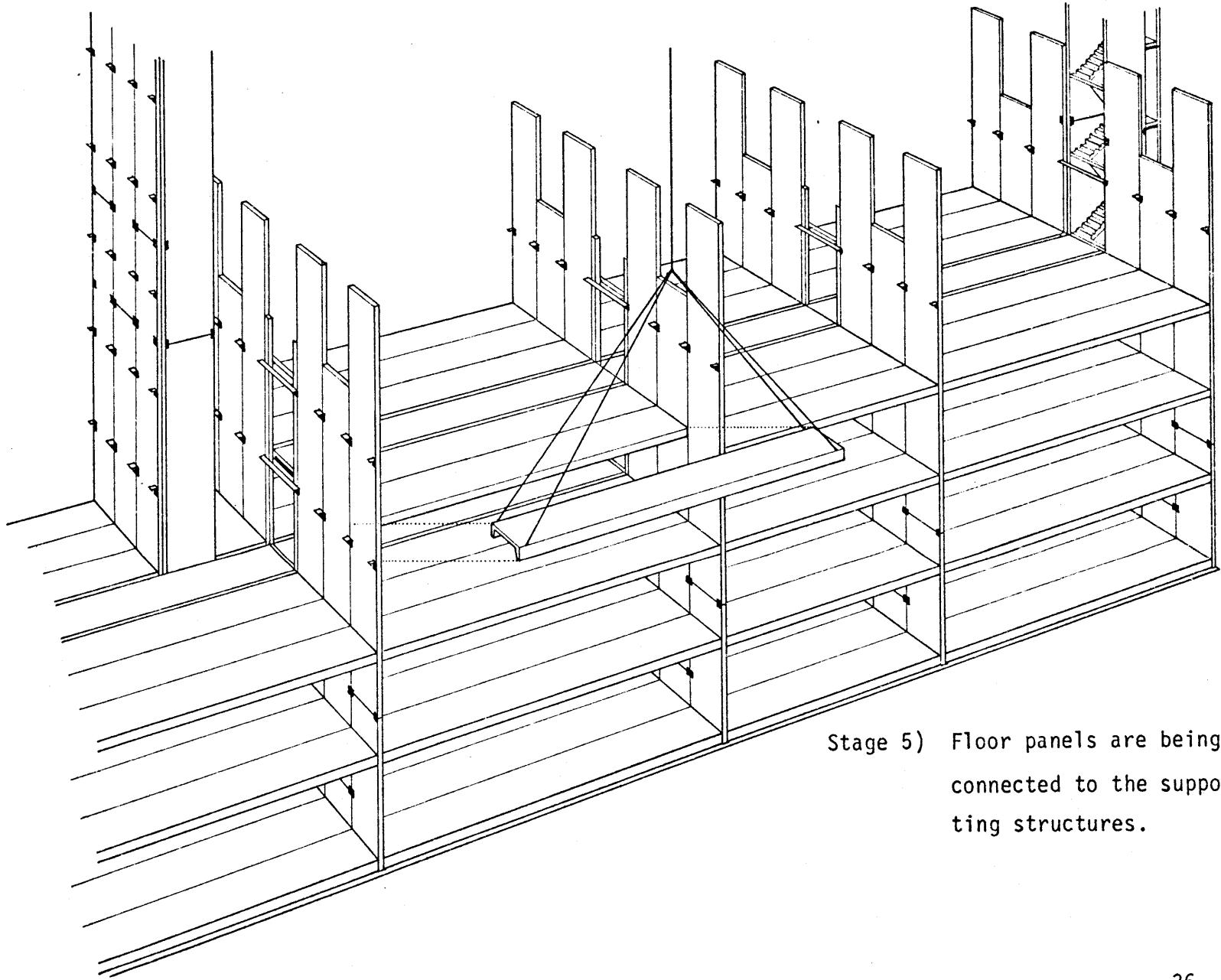

Stage 5) Floor panels are being connected to the supporting structures.

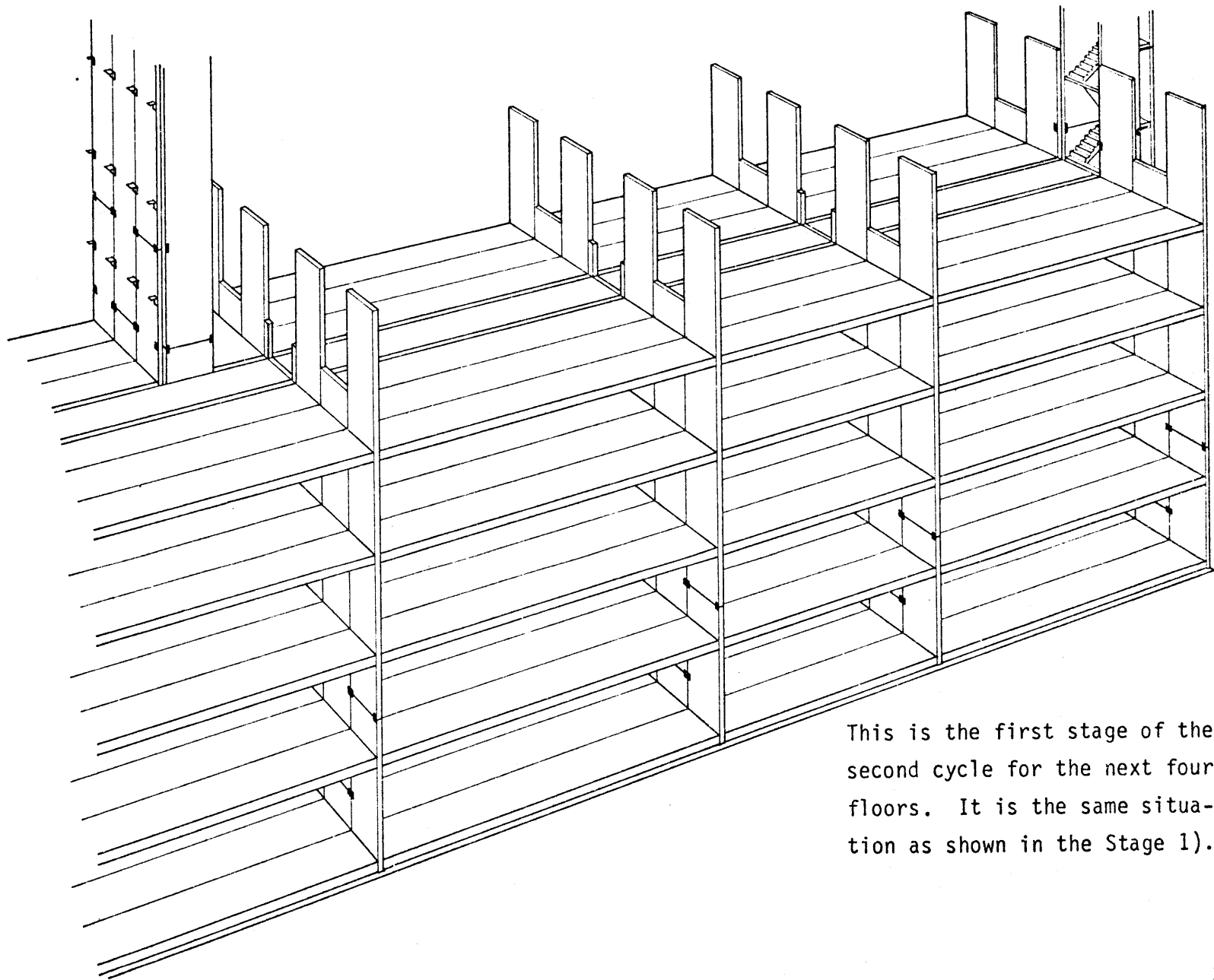

This is the first stage of the second cycle for the next four floors. It is the same situation as shown in the Stage 1).

ACKNOWLEDGEMENTS

The author owe a great deal of appreciations to Prof. Waclaw P. Zalewski for his valuable advices and critics.

BIBLIOGRAPHY

- A. Herry & W. Little, "Industrialized Housing Feasibility Study",
The MIT Press, Cambridge, MA., 1971
- A. Dietz & L. Cutler, ed., "Industrialized Building Systems for Housing",
The MIT Press, Cambridge, MA., 1971
- T. Kelly, "Composition and Properties of Concrete", 2nd ed.,
McGraw-Hill Book Company, New York, N.Y., 1973
- P. Knowles, "Composite Steel and Concrete Construction",
John Wiley & Sons, New York, N.Y. 1973
- T. Koncz, "Manual of Precast Concrete Construction Vol. 3",
Bauverlag GmbH, Wieden, Germany
- McGraw-Hill Editor al., "Structural Design Guide to the ACI Building Code",
McGraw-Hill Book Company, New York, N.Y., 1972
- G. Sebestyen, "Large Panel Buildings", Publishing House of the
Hungarian Academy of Sciences, Budapest, Hungary, 1965
- C. Testa, "The Industrialization of Building"
Van Nostrand Reinhold Company, New York, N.Y. 1972