

AN INTERVENTION IN AN EXTANT SITUATION:  
A Guideline Case-Study: Ahmedabad, India

by

ARJUN NAGARKATTI

Diploma in Architecture, School of Architecture,  
Centre for Environmental Planning and Technology  
Ahmedabad, India  
1982

Submitted to the Department of Architecture  
in partial fulfillment of the requirements  
for the degree of

MASTER OF SCIENCE IN ARCHITECTURE STUDIES

at the

MASSACHUSETTS INSTITUTE OF TECHNOLOGY

June 1984

© Arjun Nagarkatti 1984

The Author hereby grants to M.I.T. permission to reproduce and  
to distribute publicly copies of this thesis document in whole  
or in part

Signature of Author . . . . . Department of Architecture, May 11, 1984

Certified by . . . . . N. John Habraken, Professor of Architecture  
Thesis Supervisor

Accepted by . . . . . N. John Habraken, Chairman,  
Departmental Committee for Graduate Students

MASSACHUSETTS INSTITUTE  
OF TECHNOLOGY

JUN 19 1984

Botch

LIBRARIES

AN INTERVENTION IN AN EXTANT SITUATION:  
A Guideline Case-Study: Ahmedabad, India

by

Arjun Nagarkatti

Submitted to the Department of Architecture in May 11, 1984 in partial fulfillment of the requirements for the degree of Master of Science in Architecture Studies.

ABSTRACT

The objective of this thesis is to explore the possible application of the support/infill concept in the Indian Context. For this purpose, a traditional housing settlement has been selected in the Walled City of Ahmedabad.

The study has been carried out in two parts:

The first part comprises of a description of the area, highlighting the salient

characteristics of the society and a development of a typology to give an understanding of the settlement to a person who intends to intervene.

Part two consists of the design methodology, developed from the earlier made observations, suggesting directions to its application. The study deals only with the design aspects on the level of the individual dwelling.

THESIS SUPERVISOR: N. John Habraken

TITLE: Professor of Architecture

## ACKNOWLEDGEMENTS

I gratefully acknowledge the guidance and advice of Professor N. John Habraken, whose experience has been invaluable in the preparation of this study.

I wish to thank Charlotte Peed for her undue patience and for the use of her typewriter, Kadambari Baxi and Abhimanyu Dalal, for the background material, and Sanjiv Singh and Solomon Benjamin, for their assistance during the process of production.

I would also wish to thank my friends, Rajmohan Shetty, Christopher Zafiris, Laszlo Simovic, Toufic Abou Rached and Rita Sampat, for their delightful company and in making the process of writing this thesis a memorable one.

Finally, my sincere gratitude to my parents, brother and sisters, for their encouragement and the sacrifices made in order to make my study here possible.

## CONTENTS

### PART ONE

Introduction	6	Zone Analysis	55
Context	10	Range of Spaces	57
Residential Quarter	12	Capacity of Areas	59
The Dwelling	16	Staircase Variations	61
Observations	22	Transformations	63
Dimensional Typology	26	Facade Elements	64
Change	32	Application on Site	65
Territoriality	36	Concluding Remarks	67
		Bibliography	69

### PART TWO

Concept	42
Rules	45
Supports	47
Isometric View	51
Sectional Options	52
Sector Analysis	53

# part one

## INTRODUCTION

Through my studies in Architecture, housing and its applications have always taken my interest and of all its various methodologies, that which intrigued me most was the SAR Methodology. After explorations with the same, here at MIT, I felt it necessary to further my research in the same direction, so as to give myself a better understanding of the system.

The SAR Methodology, has been tested out widely in the western context and to my understanding has proved to be a very successful system. It was only when I looked to its application in the Indian context, did I realise that little research had been done to substantiate its 'workability', and hence undertook my study in that direction.

I decided to conduct my research on a tradi-

tional housing type as I felt that this type would offer greater challenges as a design issue as compared to another type, as it faces the onslaught of rapid urbanisation, resulting in the changing needs of its inhabitants. The idea of selecting a house type rather than inventing one seemed more rational because this way one can have a base towards underlining the nature of problems, thereby providing more validity to one's own decisions and value judgements.

Among the traditional housing in India, one of the interesting types would be the old residential housing lying within the walled city of Ahmedabad, and I decided to conduct my research on the same. It displays the characters of a typical traditional area, within which one observes change in the socio-cultural behaviour within an unaltered house structure. The limit-

ations of the old structure, due to inflexibility in design has not proved to be responsive to the changing needs of the people. This has resulted in the inhabitants leaving the area in search of newer dwelling environments.

The SAR Methodology has been developed over a grid system and one of my concerns in the research has been to verify its adaptability in an area that has developed organically over a duration of time. It has been my belief that the use of the SAR Methodology would encompass a variety of variations within the traditional dwelling structure which would accommodate for the growth, evident in society, which is in a process of continuous change.

It must be understood that the study, not being site specific, be viewed as a model which takes

contextual characteristics into account and incorporates them as guiding premises in a design process.

The structure of the study has been organised in the following manner:

To begin with, the intention is to give the reader a broad overview of the walled city of Ahmedabad, capturing the developments that have taken place during the process of its evolution. Having set the contextual background, the study of the residential area comprises of the next part giving characteristics of the population, income and type of densities, finally leading to the general observations and a typology study of a typical dwelling.

The topics concerning change taking place within the society and transition zones observed

within the dwelling, have been mentioned, as being important issues to be considered during the process of design.

The second part essentially deals with a design exploration of the support system on the basis of the earlier made typology. Certain necessary rules, deciphered from the first part, are to be used as guiding premises in design. The design is conceived of as being an interpretation that could be possible adhering to the rules.

Ultimately, the intention was to formulate some comprehensive principles for the residential area in the walled city, so that any designer who has to intervene in this area or a similar one, can find it useful in developing his own approach.





# CONTEXT

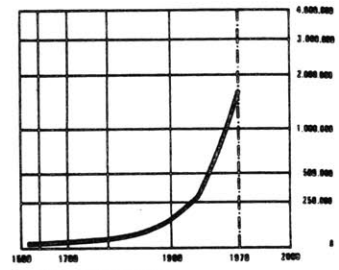
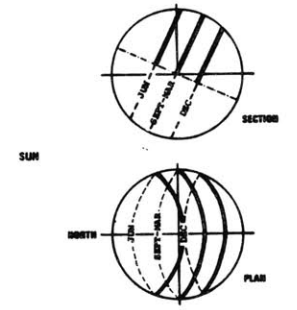
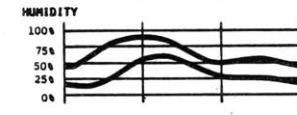
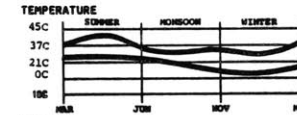
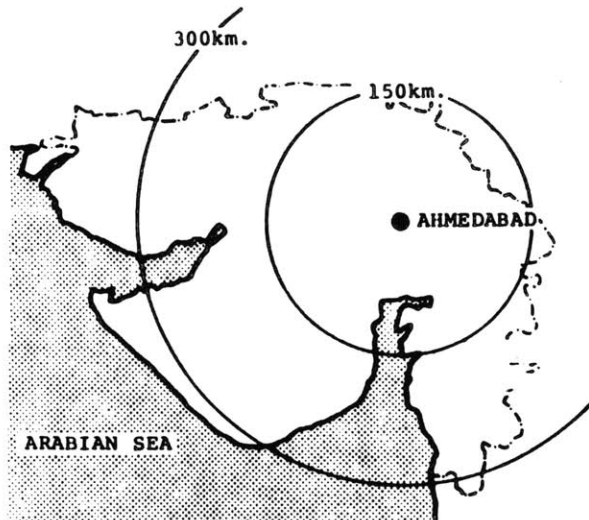
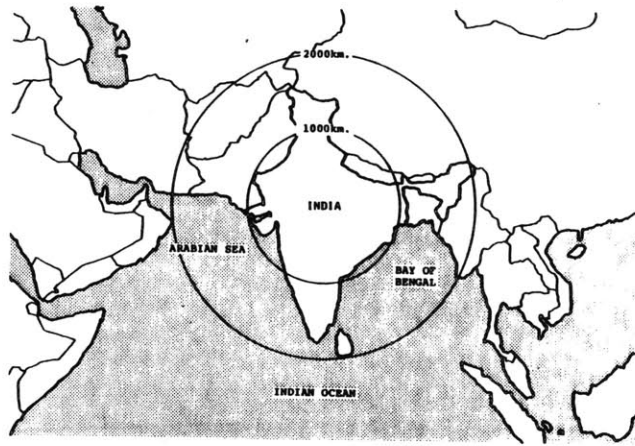

**URBAN POPULATION GROWTH**  
horizontal: dates vertical: population  
Source: Himish Patel, M.I.T. Thesis, 1976.

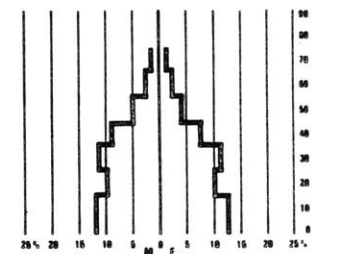

**URBAN POPULATION DISTRIBUTION**  
horizontal: percentages vertical: ages  
males: M females: F  
Source: Himish Patel, M.I.T. Thesis, 1976.

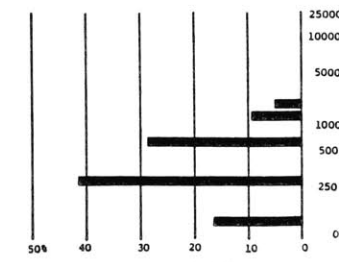

**URBAN ANNUAL INCOME DISTRIBUTION**  
horizontal: percentages vertical: dollars  
Source: Himish Patel, M.I.T. Thesis, 1976.

### History of Ahmedabad - The Walled City:

The city of Ahmedabad was founded as a capital in the year 1411 A.D. by a Mughal ruler Sultan Ahmed Shah, on the eastern banks of the river Sabarmati, on an important trade route intersection.

The city during the early 15th century was comprised of a main fortified area around the King's palace and a number of separate fortified suburbs called 'Puras' outside the city, which housed Mughal officers and their entourage. They were self contained units, each having their own markets, water supply systems (underground reservoirs) and place of worship. As the commercial activities developed, these puras grew in population and expanded to join others, resulting in a new wall being built around the whole area to form what is today known as the Walled City.

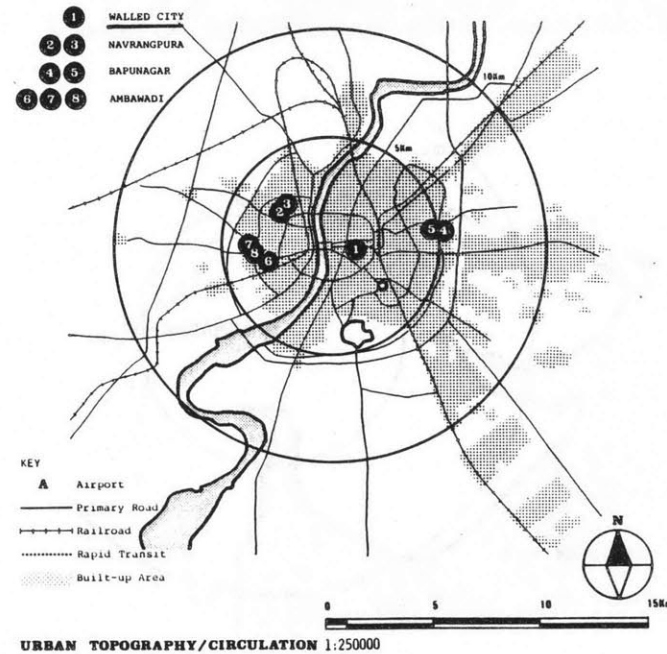
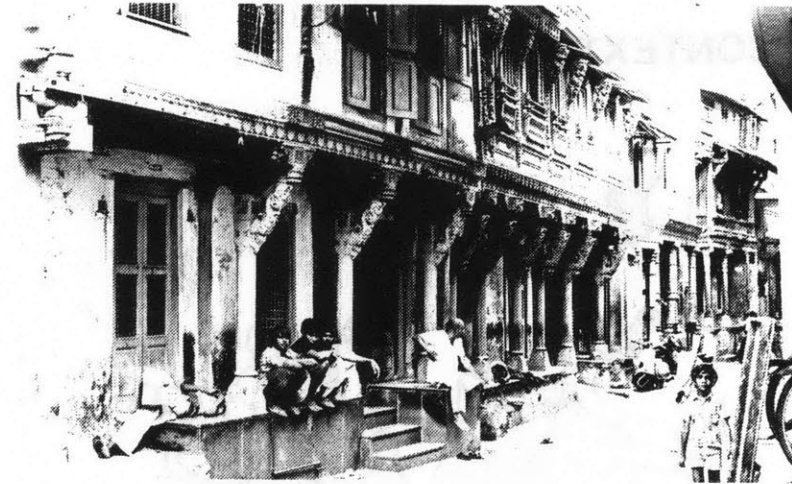

## RESIDENTIAL QUARTER

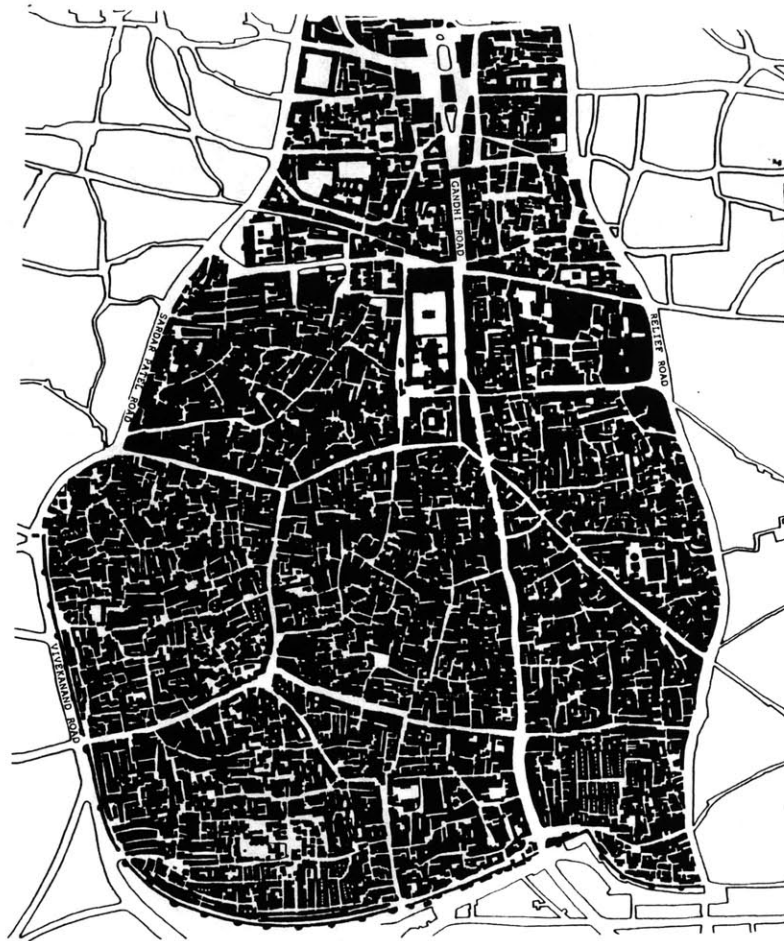

PLAN SHOWING THE WALLED  
CITY OF AHMEDABAD



The entire residential area enclosed within the fort wall has grown organically over a period of 2-3 centuries. It is situated on the periphery of a commercial zone and is seen branching off from the main substreets which are often commercial in character. The original residents have moved and have been replaced by the ones tied together by caste, religion, profession, business or craft and each of these are located near their predominant work place in the commercial area of the city. The incremental growth of the 'pol' has resulted in a geometrically arbitrary pattern of streets governed by ancient canons of street planning in India. Each 'pol' is a closed loop which terminates in the form of an open space surrounded by dwellings and generally referred to as a 'chowk'. The land subdivision is very irregular and in most cases the entire lot is covered by building construction.

The houses are placed next to each other on the sides, to avoid the heating of the walls by direct radiation and very close to each other in the front to create shaded streets, as a protection against the hot dry climate. The reasons for forming the looped streets was to protect the interests and privacy of different ethnic groups.

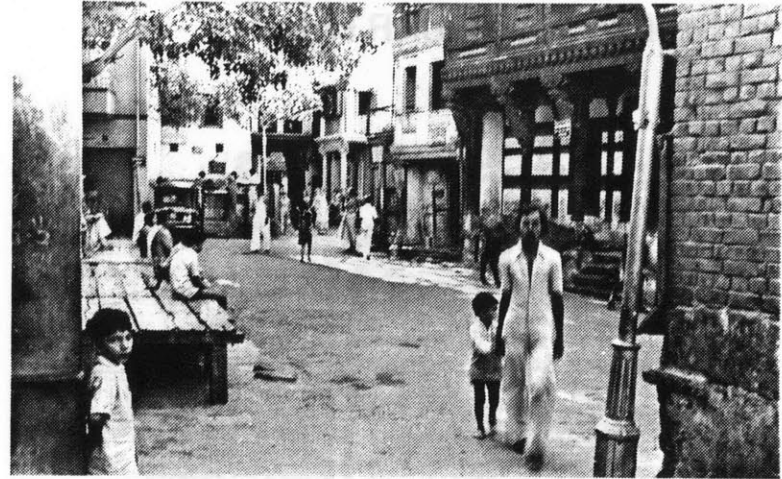

The following page has an example of a typical traditional residential area in the city of Ahmedabad. It is a combination of many such 'pols' along with the commercial area which constitute the walled city. The land utilization data, percentages of open to built, population density and the average income of residents have been mentioned, to give the reader a general over-view of the area in question.

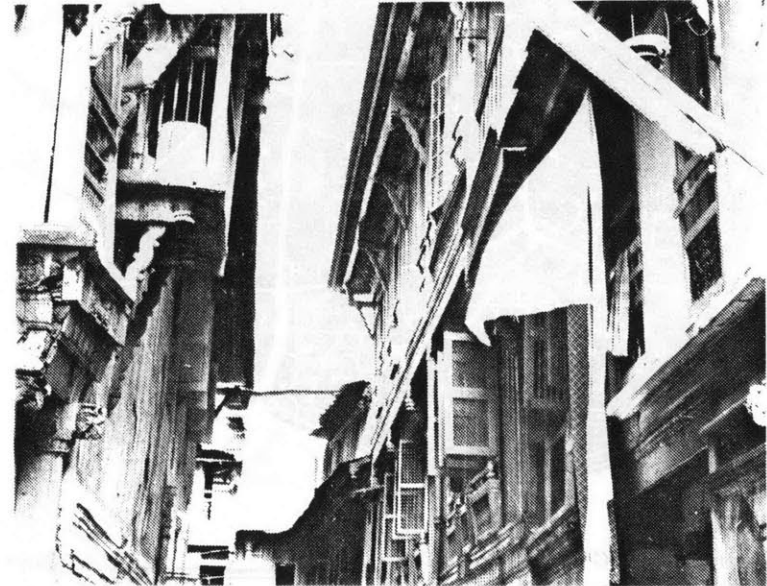



A TYPICAL  
RESIDENTIAL AREA



#### Population and Income:

In 1971, 30% of the city's population lived in the walled city. In the past, upper middle and high income extended families lived in the locality. Many of them have moved to suburbs, renting their houses to middle income people. A majority of the new occupants are connected to surrounding commercial areas. There is a great degree of cohesion and interaction resulting from grouping based on common interests. The annual family income ranges from U.S.\$800 to 2,000 (3 to 5 times the subsistence level), a large sector of the population has an average annual income of U.S.\$1,100.

#### LAND UTILIZATION DATA

AREAS	Hectares	Percentages	DENSITIES	Total Number	Area Hectares	Density N/ha
PUBLIC (streets, walkways, open spaces)	0.19	16	LOTS	109	1.21	90
SEMI-PUBLIC (open spaces, schools, community centers)	-	-	DWELLING UNITS	123	1.21	102
PRIVATE (dwellings, shops, factories, lots)	1.02	84	PEOPLE	711	1.21	588
SEMI-PRIVATE (cluster courts)	-	-				
TOTAL	1.21	100				

source: Nimesh Patel, MIT Thesis 1976.



1 Hectare

**PATTERN**

- Public: streets/walkways
- Semi-public: playgrounds
- Semi-private: cluster courts
- Private: lots
- dwellings

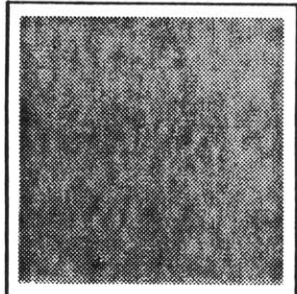

**PERCENTAGES**

Streets/Walkways	16%
Playgrounds	-
Cluster Courts	-
Dwellings/Lots	84

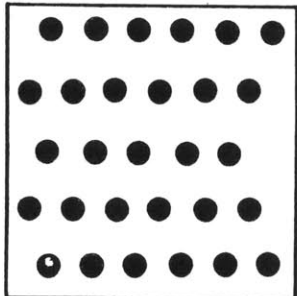

**DENSITY**

Persons/Hectare	588
-----------------	-----

20 Persons



source: Nimesh Patel, MIT Thesis 1976.



## THE DWELLING

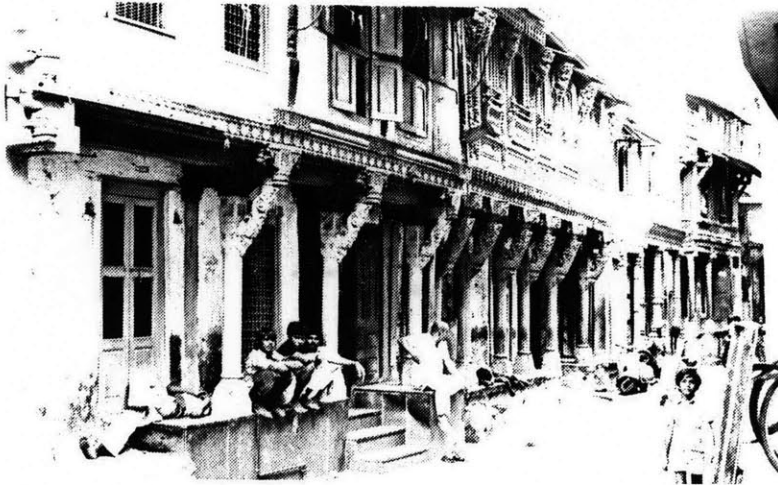

The 'pol' dwelling can be typified as being a courtyard house consisting of a 3-4 level structure of wooden post and beam construction with a brick infill. The availability of wood in the past, encouraged its use to the extent that people used it to carve our decorative panels which were placed on the facade wall.

The entrance to the dwelling is over a high plinth which leads into the first room. This room usually has access by way of a staircase to the above room which in most cases is let out. The lower room usually has a toilet positioned closer to the entrance to service the residents, as in earlier days, it was customary to wash one's feet before entering the house. This toilet is also used by the tenant as it is not uncommon to have no toilets on the upper storey due to there being no piped water



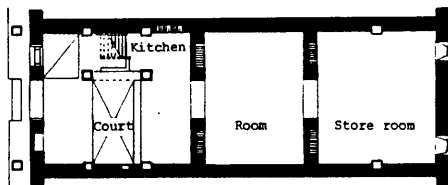
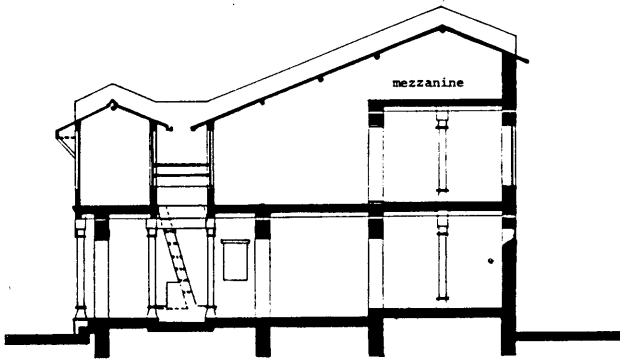
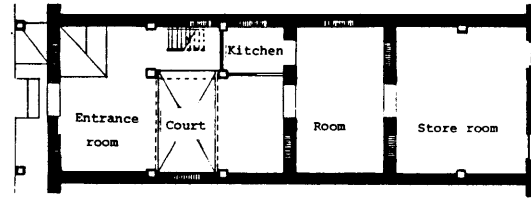
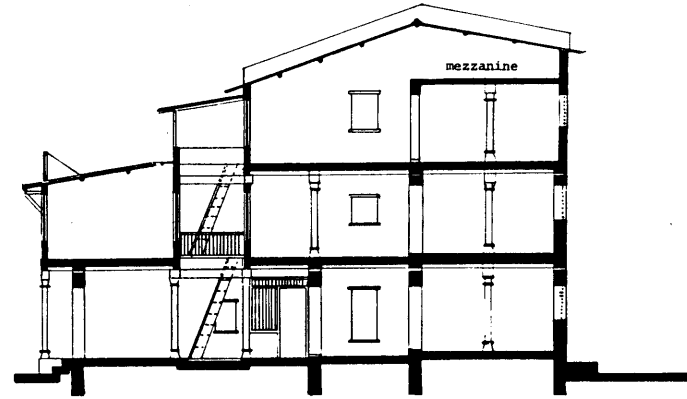
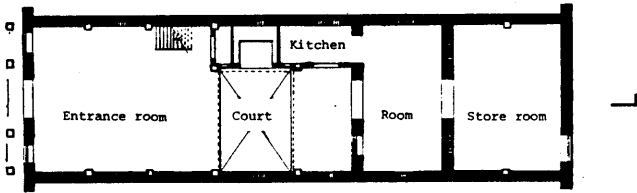
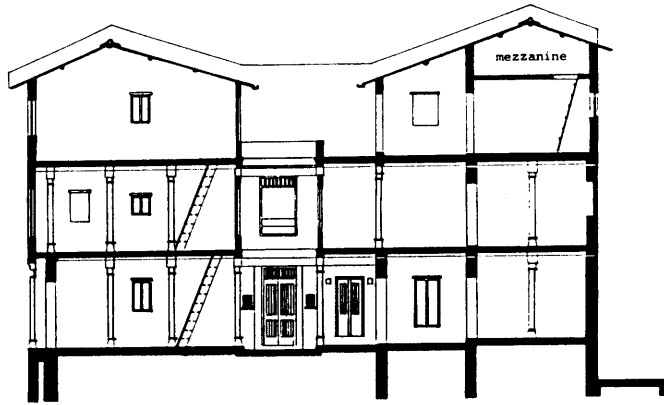

TYPICAL DWELLING UNITS

0 1 3 6 metres



Areas around the court are used for cooking

and proper drainage. One then enters the court area which is brightly lit and ventilated. The courtyard is usually placed about the centre of the dwelling and is open to sky, with the rooms at the upper levels opening out into the court by way of windows. The court has around it, semi covered areas which are used as a living area and an area for cooking. The court is serviced by a washroom or a toilet which is in easy access for the residents. It sometimes has a prayer room which has a dimension of 1x1.5 metres, with icons placed within them. The court is a very important space as it acts as a ventilation shaft to relieve the summer heat. There may be the presence of a stairway to provide private access to the residents of the unit, should the front part of the second storey be let out. The court is elaborately decorated at the upper levels, by wooden facade

panels which is believed to scatter light at those levels, thus reducing the glare in the court. The areas beyond the court are rooms which are used for storage and sleeping. The room at the rear is used as part storage and for sleeping in the winter time, as it tends to keep warm due to lack of openings. The upper floors have larger rooms which open out in the court by way of a terrace. The terraces are usually closed at the second storey by windows and open at the third storey. The top storey has usually the presence of a mezzanine level, positioned under the roof, and used as storage. The roof is sloped and tiled over wooden rafters. There is usually a small terrace, at the upper storey which is used for sleeping in summer nights and during the kite flying festival.

It must be understood that the areas in the

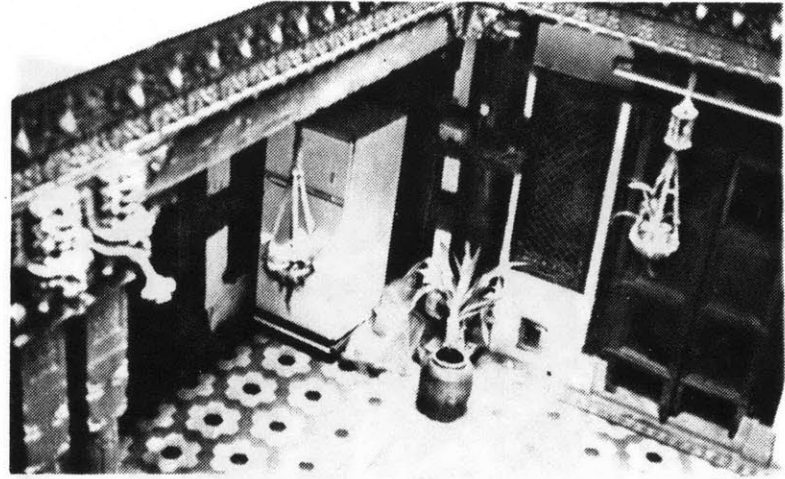

The court within the dwelling

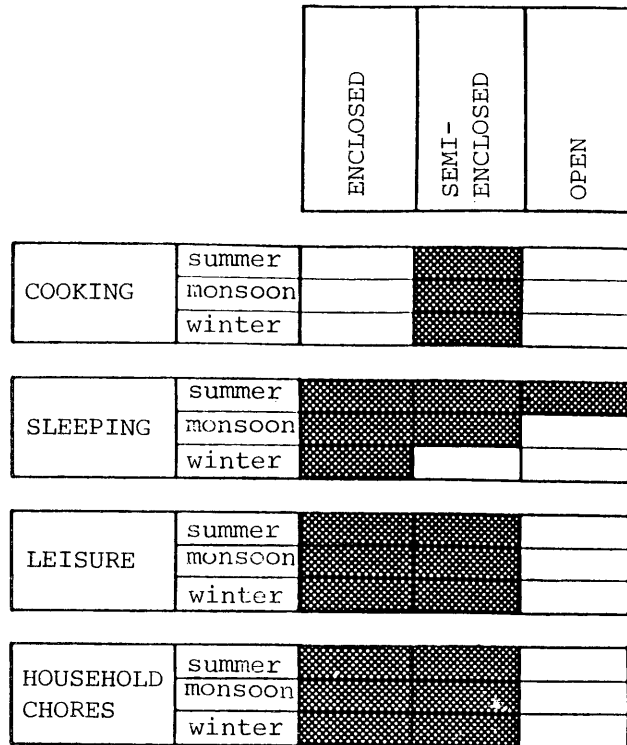

dwelling are multiuse and depending on the weather and the number of people living in the house, the use of each room would vary.

The chart displays the activities that take place in different areas of the house. Enclosed areas would include the rooms, semi enclosed areas would be the area around the court and open should be understood as the court area and the terraces.

The observation models on the following pages are to give the reader a basic understanding of the sequencing of areas and the location of stairs, kitchen, and toilets in the unit. The sequence of the elements around the court is shown to give an idea of the importance of the space as being a generator of activity.



# OBSERVATIONS

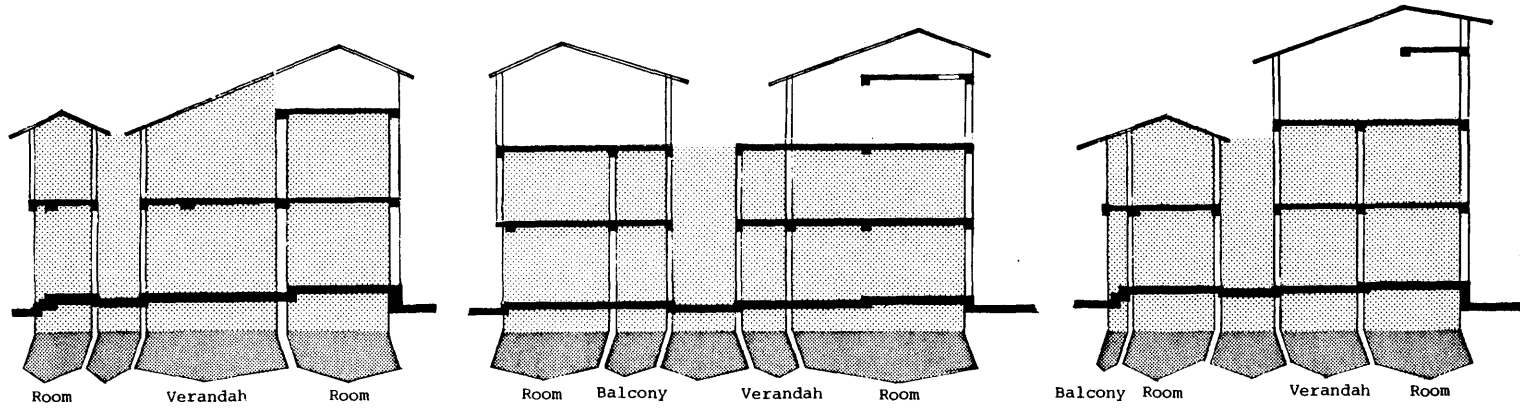

## UPPER LEVEL

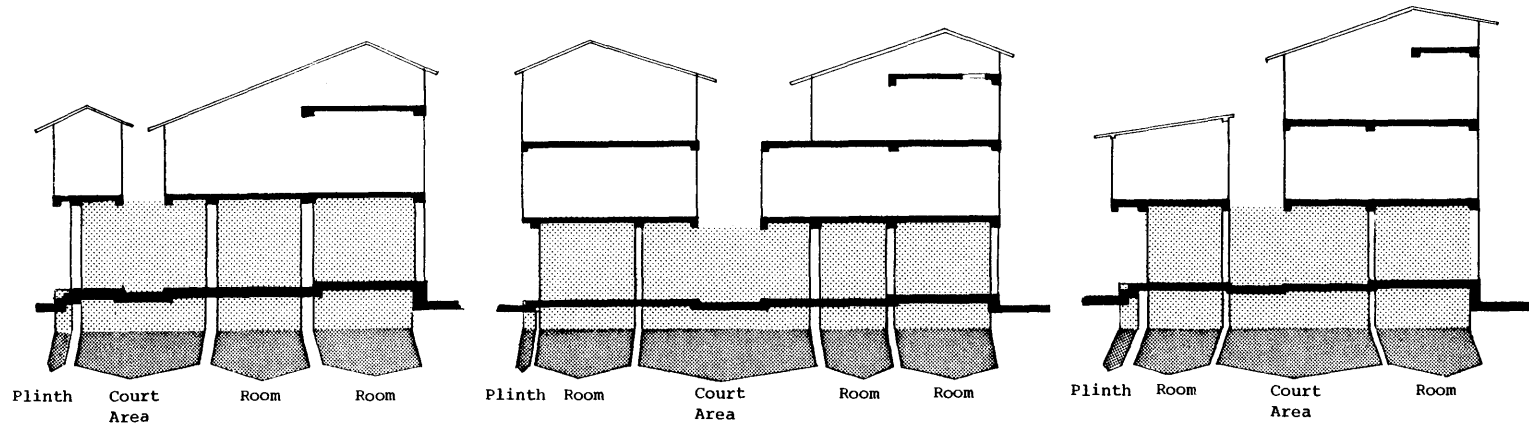

## LOWER LEVEL

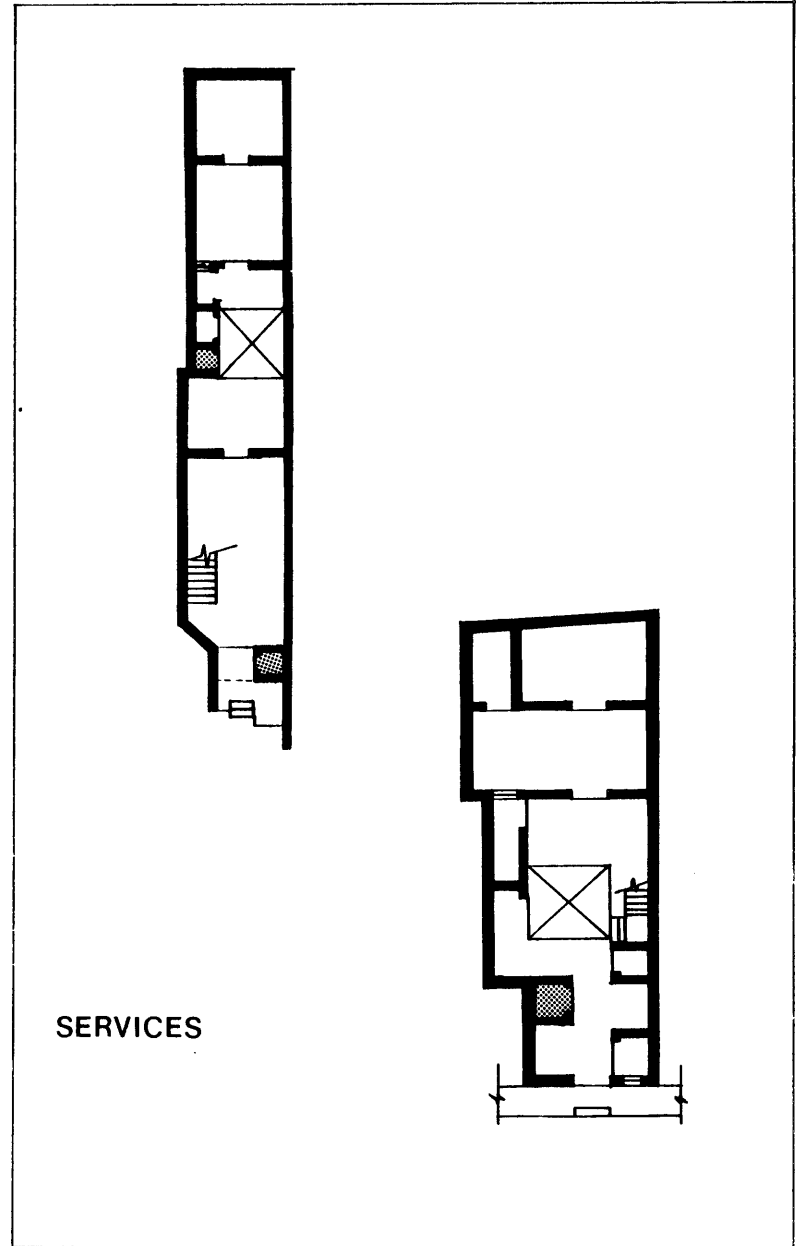
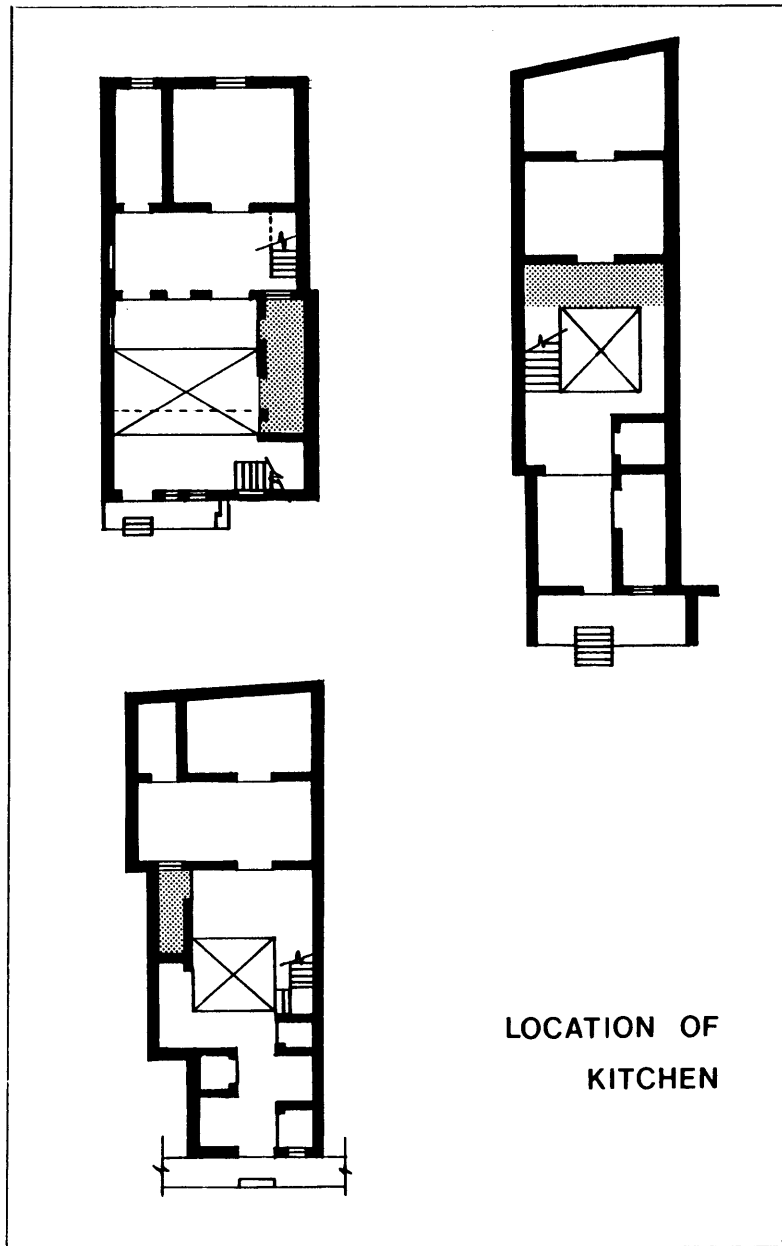

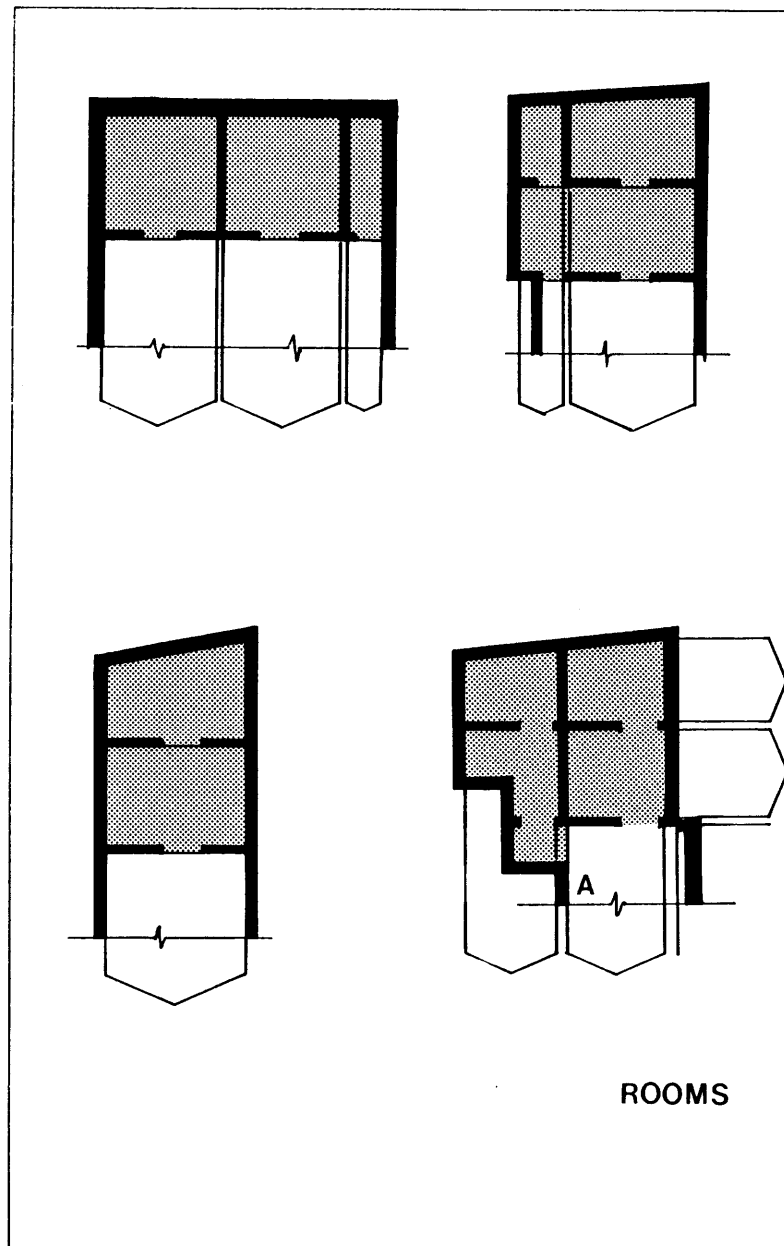
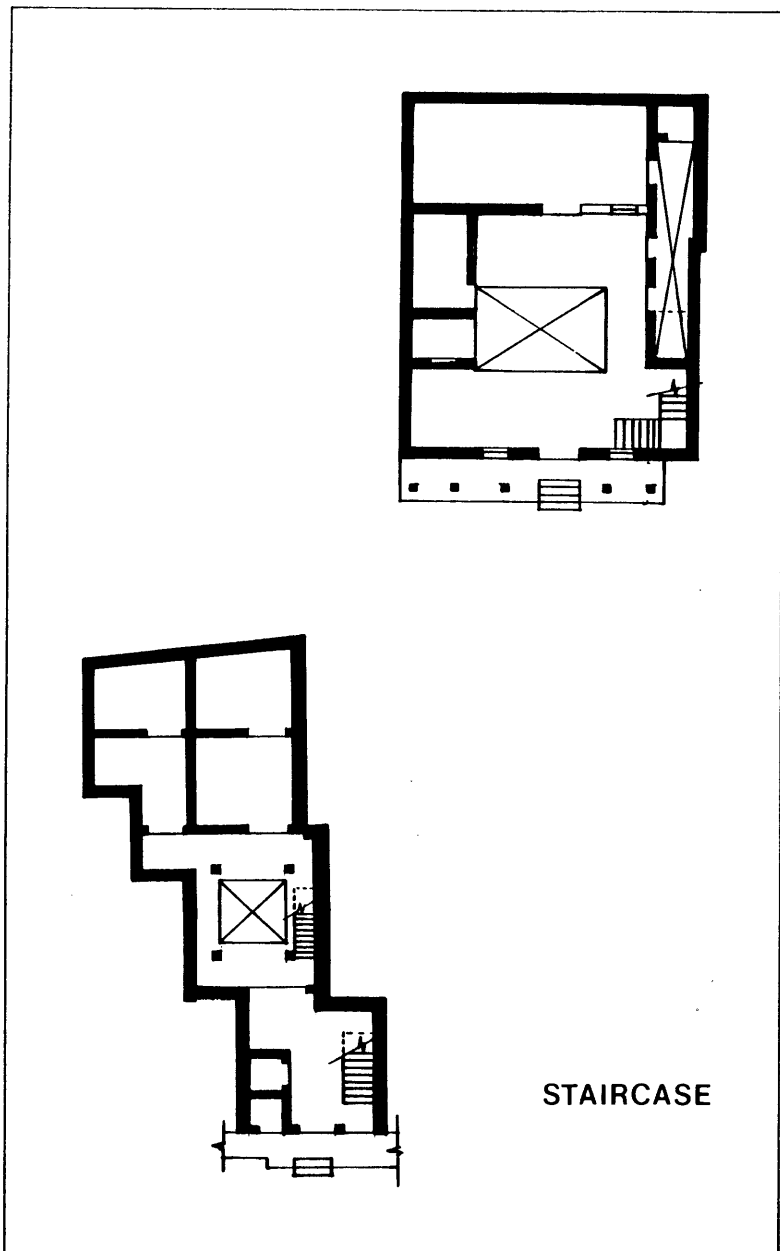



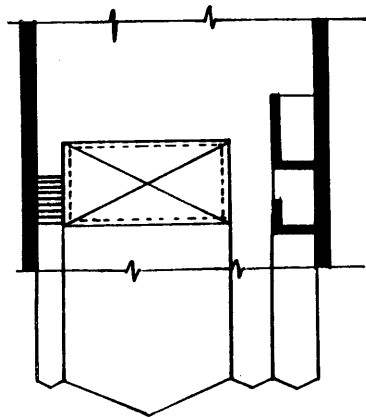

S  
T  
A  
I  
R  
R

C  
O  
U  
R  
T

P  
A  
S  
S  
A  
G  
E

R  
O  
O  
M

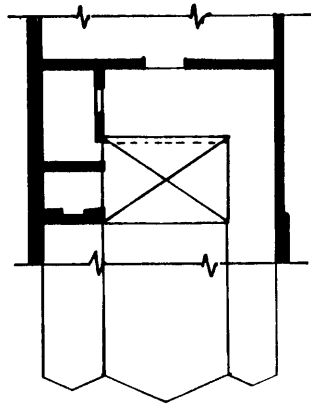

R  
O  
O  
M

C  
O  
U  
R  
T

P  
A  
S  
S  
A  
G  
E

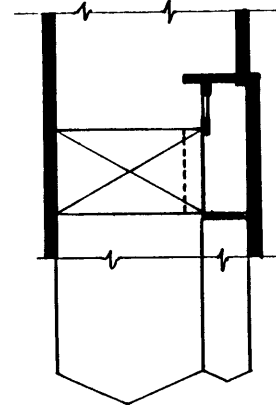

C  
O  
U  
R  
T

R  
O  
O  
M

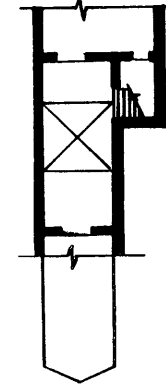

C  
O  
U  
R  
T

**SEQUENCE OF ELEMENTS  
SITUATED AROUND THE COURT**

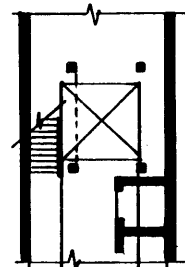

S  
T  
A  
I  
R

C  
O  
U  
R  
T

P  
A  
S  
S  
A  
G  
E

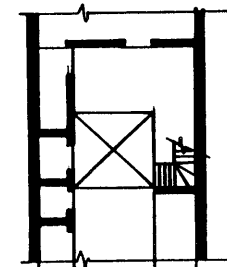

R  
O  
O  
M

C  
O  
U  
R  
T

S  
T  
A  
I  
R

## DIMENSIONAL TYPOLOGY

The development in the residential area has taken place in an additive manner and has resulted in people building on any available space. As a consequence, one observes varied dwelling types, having similar plans and making the settlement very rich in character.

The purpose behind exploring the dimensional typology of the dwelling types, is to isolate elements involved in the process of space making and hence identify the relationships between them. Being a courtyard type of dwelling, I would begin by identifying it, thereby stressing its importance in the unit, and later discuss the other areas,

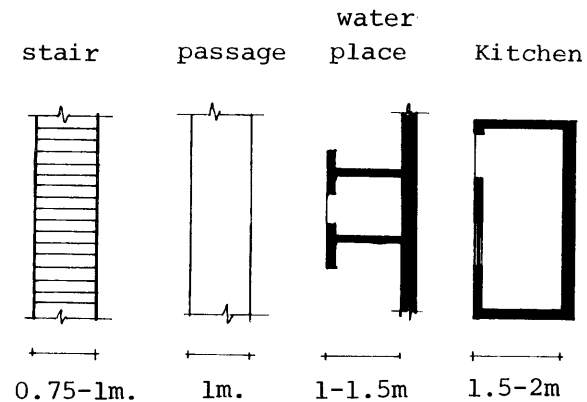

ELEMENTS

As seen in the earlier developed typology, the court is placed towards the centre of the unit, flanked by rooms at the rear and an entrance

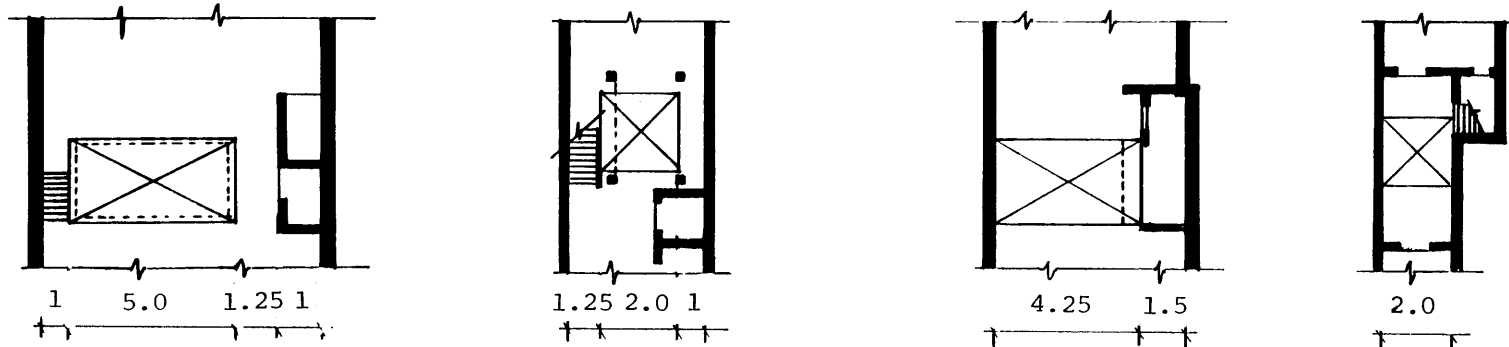

room at the front. The width of the unit varies from about 8 metres to 2.75 metres depending on the size of dwelling and is what determines the supporting elements. The elements in question would be the stairs, passage, and the small room. It is assumed that the dweller would position an element or a combination thereof, depending on the available width in the dwelling. The dimensions of the elements are fixed whereas that of the court is flexible. Larger

widths would accommodate more number of elements whereas there would be a space restriction in the case of smaller widths resulting in a limited choice of elements.

The sequence of positioning would be as follows: The court would get the highest priority and depending on the amount of light and ventilation required, its minimum size would be determined. The remaining area would be

UNIT	WIDTH	COURT	dim.	STAIRS	dim.	PASSAGE	dim.	ROOM	dim.	no. of elements
A	8.25	●	5.0	●	1.0	●	1.0	●	1.25	<u>4</u>
B	7.50	●	5.0			●	1.0	●	1.5	<u>3</u>
C	5.75	●	4.25					●	1.5	<u>2</u>
D	5.50	●	2.75			●	1.0	●	1.75	<u>3</u>
E	5.0	●	2.5			●	1.0	●	1.5	<u>3</u>
F	5.0	●	3.0	●	1.0			●	1.0	<u>3</u>
G	4.25	●	2.25	●	1.0	●	1.0			<u>3</u>
H	4.0	●	2.0			●	1.0	●	1.0	<u>3</u>
I	3.75	●	2.25	●	0.75	●	0.75			<u>3</u>
J	2.75	●	2.75							<u>1</u>

- measured in metres.

allocated to the elements depending on the need. On positioning the elements, the remaining area in excess being too small to accommodate another element, would be utilized by extending the limits of the court, thus making it the flexible element. This would be the decision taken, rather than increasing the dimension of the elements. The court being a multifunctional space, could utilize additional area which could

be functional. One would observe that in the narrow houses, courts do not have supporting elements, as the width only satisfies the minimum dimension required by the court. The table above, is a survey from ten units to be found in the residential area which satisfy different conditions, with respect to the width of the dwellings.

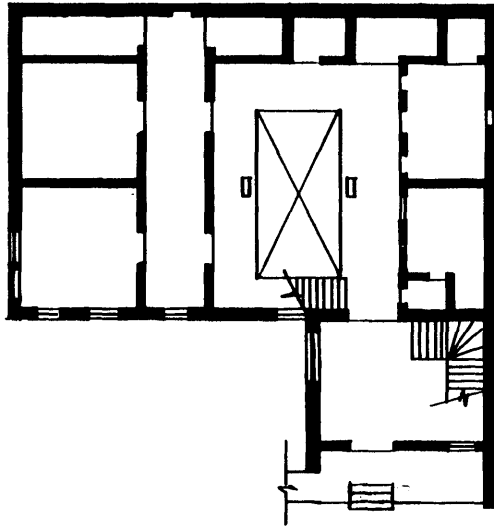

UNIT WITH CENTRALLY PLACED COURT

In larger dwellings, an attempt is made to place the court in the centre so as to have area along the walls to be able to position the elements.

The dimensioning of the rooms seem comparatively simple as the average size of room, at the rear end of the dwelling would be 4 metres by

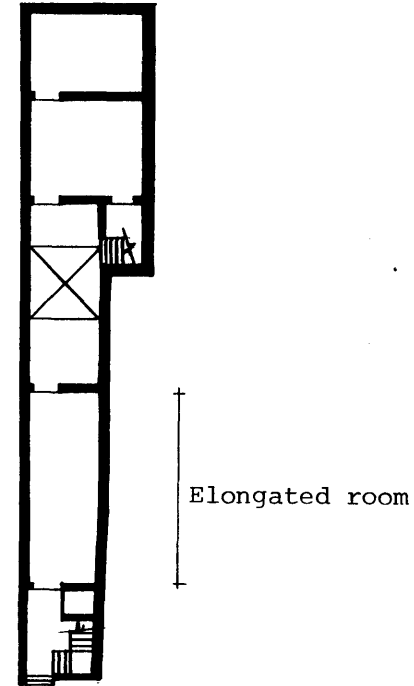

4 metres. In cases where one has more area, either a second room is added, of the same dimension, or the area is converted into a store room.

The size of the room in the front is the result of the positioning of the court. In long units,

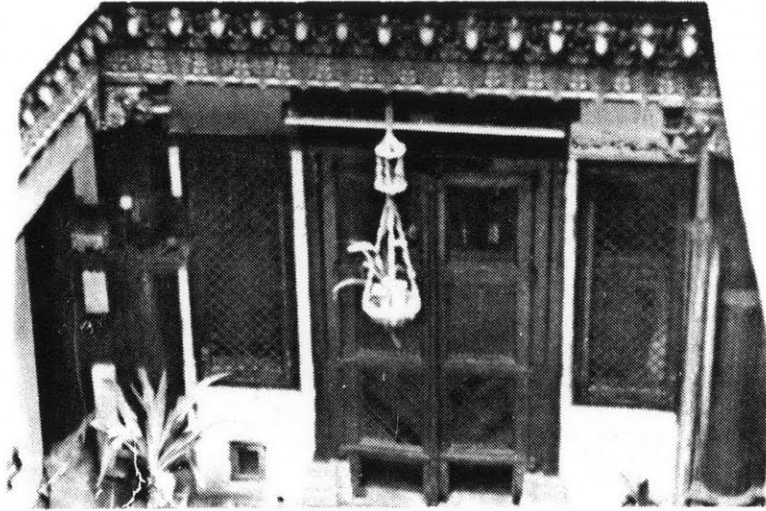

court area

the court is positioned closer to the rooms at the rear, to provide for light and ventilation. The area in excess is accommodated within the area of the front room which gives it an elongated shape. In houses that have less depth, the front room is eliminated to provide for greater area around the court. Thus with respect to the depth of the dwelling, it is the front room that is flexible to change.

It can therefore be seen that a dwelling which does not conform to a fixed set of rules with respect to its boundaries, has developed within the unit, areas that are flexible to change, as the situation demands, thereby ensuring that the basic typology by maintained.



## CHANGE

The residential area has been undergoing a lot of change due to various forces like rapid urbanization, change in the social structure and in the technological status of the society.

Urbanization has resulted in increased densities and the effect is felt in streets which originally designed for pedestrains, now take vehicular traffic, resulting in problems of crowding. This is the consequence of the neighbouring commercial area infiltrating the residential zone.

The change in structure would include the break-up of the extended family into a nuclear one. A residential dwelling was originally occupied by an extended family, but due to changing trends and the need for privacy, people have left the area in search of independent family





dwellings. This has resulted in part of the dwelling being let out to outsiders, by some poor families in order to supplement their income. In such case the tenant would tend to intrude on the landlord's privacy by using the common services generally located around the court of the first storey. At times entire floors would be rented out and the tenants would have to pass through the house on the lower storey. Lack of infrastructural facilities have

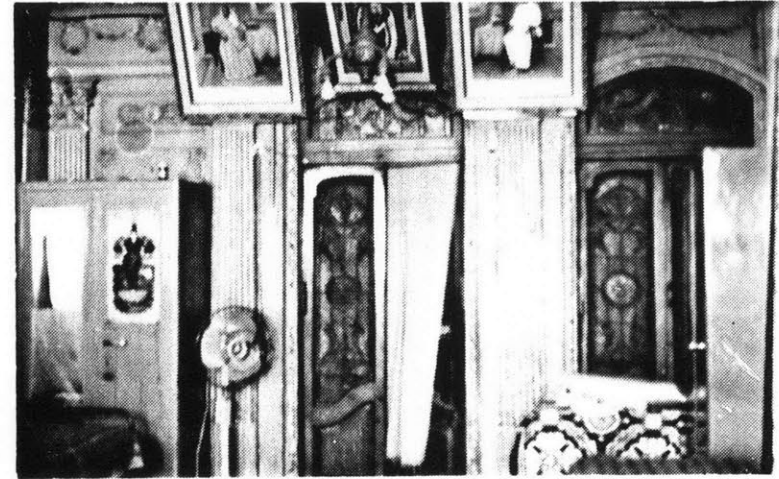

left the tenants no choice but to convert the wash areas into toilets.

Among other changes it would be necessary to mention the change with respect to the use of areas within the dwelling. The room at the rear end of the dwelling, originally used as an area to store grain, thus requiring little light and ventilation, is presently being used as a living area. The old 'sitting kitchen' has

been transformed into a modern one by the use of kitchen platforms, to accommodate the recently introduced gas range and other appliances. The second room from the rear, intended primarily as a sleeping area is now converted in some dwellings to serve the purpose as a dining room. Thus it can be seen that areas which were earlier 'multi-use' in function are now being formalized with respect to the activities taking place.

Industrialization and technological progress have contributed to innovation of new materials and techniques of construction. The latest structures are of reinforced cement concrete, often with three or more storeys which attempt maximum use of the FAR.

It would thus seem necessary for a designer to

incorporate these changes should one have to intervene.



## TERRITORIALITY

The residential dwelling displays a strong sense of territoriality which has developed over time. due to the prevalent social structure. One would believe that these boundaries were created due to there being a closely knit society with each dwelling having a number of people living together as an extended family, consequently there being many common areas and few private ones. These territorial margins were implicit and were recognised by the residents. The disintegration of the extended family, threatened the traditionally accepted boundaries that existed within a dwelling, as rooms and sometimes entire floors were being rented out to people outside. Thus in some dwellings new territories developed in an attempt to counteract this change.

In this section, I would discuss the territories

both in the traditional setting as well as highlight the effects created by the change in the family structure.

An extended family generally live in the entire dwelling consisting of two to three stories.

The various floors are connected by an internal staircase to provide access to the commonly used areas , such as the kitchen, the living area, the prayer room, the court and the toilets.

It is not uncommon to find all the toilets situated on the first floor and there being only wash areas on higher floors. The rooms are primarily used for sleeping or for storage. Thus within the family dwelling, one could consider the rooms as being private to its user/s, the other areas being shared by the residents.

There are different territorial limits to the

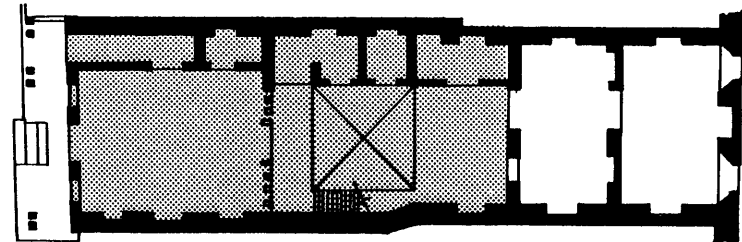
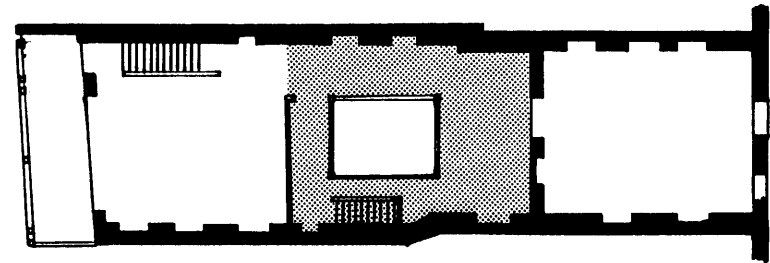
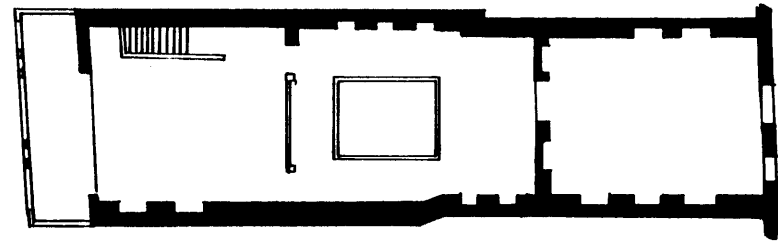

 Common Area  
 Private Area

0 1 3 6 metres



court as a demarcater  
of the territorial limit.

guests  
and acquaintances.

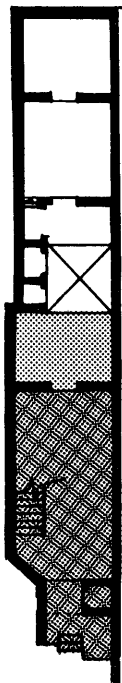
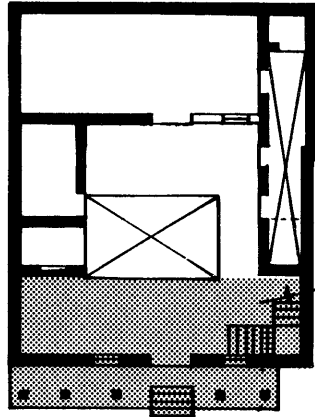

court as a  
demarcater  
limit for guests

limit for 'passing  
acquaintances'

people outside the immediate extended family which varied depending on one's familiarity with the dwellers. An acquaintance would be entertained in the room towards the front end of the dwelling while a guest of the family would be asked into the court area. In cases where there is no physical distinction between the room and the court area, it is the court that is understood as being the divider, of the two public/private domains. In this case the kitchen area would not be spread over the area around the court but would be restricted to the area towards the rear of the dwelling, thus implying its association with the private domain.

This territorial organization is disrupted with the introduction of a tenant, who has to pass through the landlord's house, to get to the

Second Floor

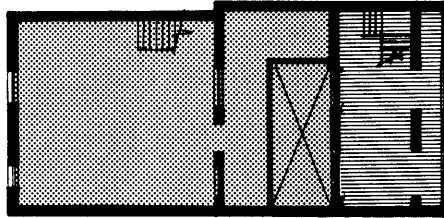

First floor

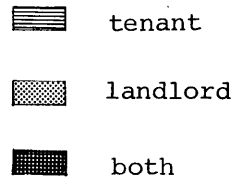
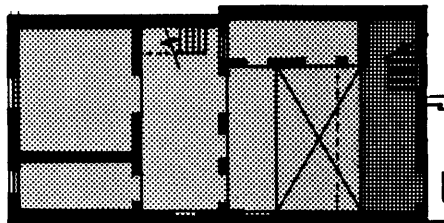

TERRITORIAL LIMITS

room on the second storey. The landlord would therefore erect another staircase around the court to gain access to the rear room on the higher floor. A screen wall would be introduced between the court and the rear room in cases where there is no physical territorial distinction between the front room and the court.

There exists a definite hierarchy of spaces bet-

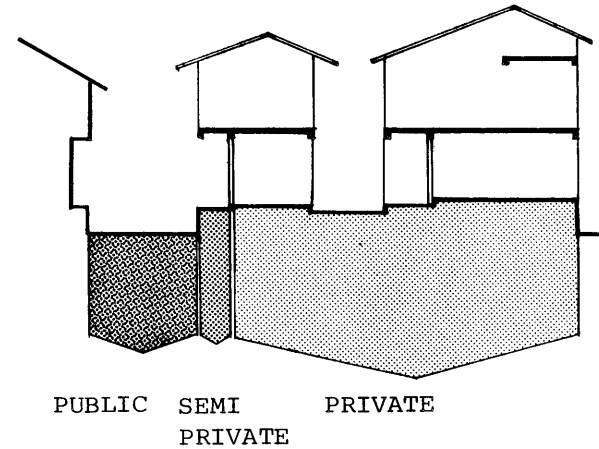

ween the street and the dwelling unit, which can be categorised as follows: street - public; raised plinth - semi public; and dwelling - private.

Due to infiltration of commercial activities in the residential zone, part of the plinth is used as a shop area, thereby making the plinth a public area. This is seen by the resident as an

infringement on one's privacy as one is confronted by a public zone on stepping out of one's dwelling.

One observes that the change in the social structure has inevitable repercussions on associated activities, resulting in one having to make compromises and adjustments in an attempt to maintain the earlier existing congenial environment.



**part two**

## CONCEPT

The concept of the design essentially evolves around a support structure that would accommodate basically three types of units, such that there lie options for the buyer as to size of unit depending on the affordability. Variations in this plan make available, a variety of areas, depending on the requirements of the family. The dwellings rise to three storeys and would allow within its structure, a number of variations in areas of rooms, with the possibility of dividing a house into sub-areas, in order that it may be let out to a tenant.

The process has been conceived along the lines of evolutionary housing strategy and that the dwelling develops according to the changing needs of the inhabitants. This process has been adopted as the structure of the households in the context have been observed to change

radically in time. What makes the strategy more realistic than providing finished houses is that since there is a high level of user participation, the developer has to build less than both the user and the developer can afford and the user can add more, as and when required.

The models developed are conceived as being flexible enough to be applicable in pockets of existing well located, but dilapidated areas, and applicable in new developments.

The process of development would be as follows:

Stage I: The developer/builder sells the dwelling in the form of a support structure.

The buyer has the option of different areas, depending on the affordability. Once the total area of the dwelling is determined, partition walls are erected to demarcate the limits of

the unit along the perimeter.

Stage II: The owner of the dwelling, with the help of masons and carpenters, erect partition walls within the dwelling on the first floor, after deciding on the area required in each room.

Stage III: At this stage a decision is taken as to the form of the street and the permissible extension of one's plinth to create a non-linear street pattern. This decision would have to be made in consultation with one's neighbours and the residents on the opposite side of the street, as the minimum width of the street, as stated in the rules is 6 metres.

Stage IV: A decision would be made as to the positioning of the court after which the required areas on the upper level would be determined.

Stage V: At this stage, the stairways would be positioned depending on the family structure

and the rooms that are let out to outsiders.

Stage VI: After the basic areas are worked out.

the owner then decides as to the areas of the

terrace required and finally constructing the

roof.

**RULES**

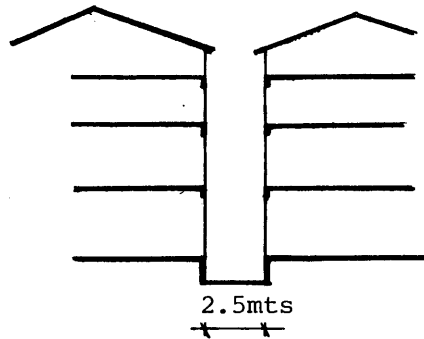

RULE I: The alley between two units should not be less than 2.5 metres.

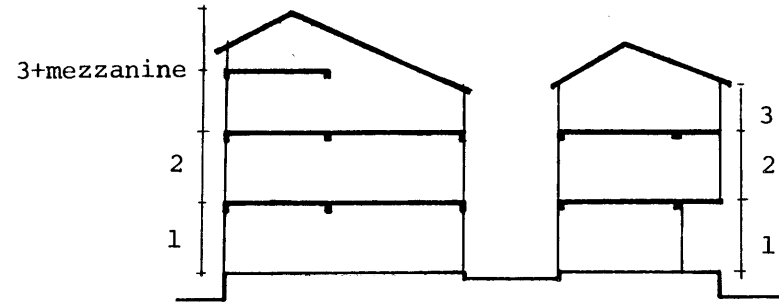

RULE III: Maximum allowable height should not exceed three floors in front and three plus mezzanine at the rear.

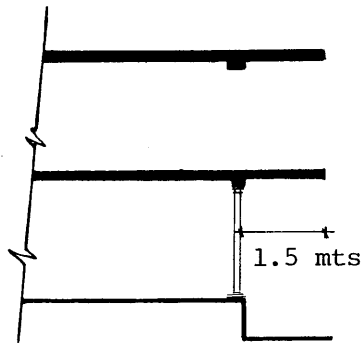

RULE II: The cantilever should not exceed 1.5 metres from the column at the entrance plinth.

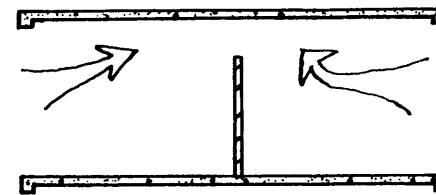

RULE IV: To allow for ventilation in the rear room, the wall should stop short of the ceiling.

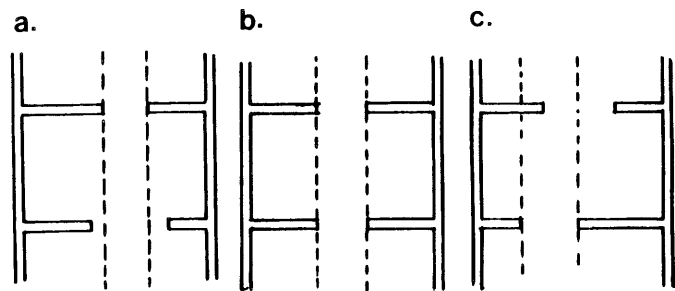

RULE V: Doorways should never be staggered - case 'c' would be not permissible.

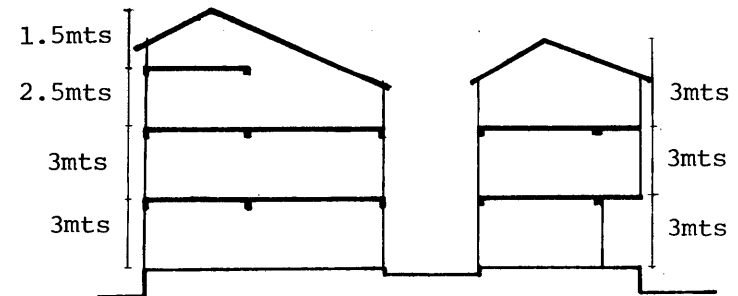

RULE VI: Floor to ceiling height would be 3 metres except in the case when there is a mezzanine floor which would have a 1.5 metre height, while the rest of the floor having a height of 2.5 metres.

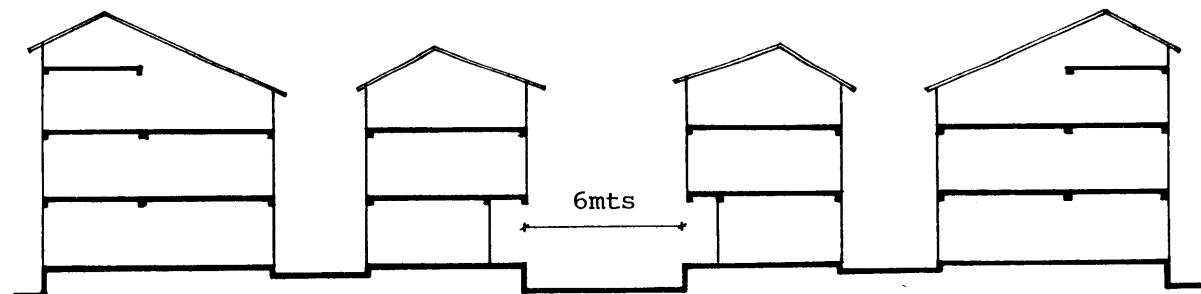

RULE VII: The width of the street should be maintained at 6 metres. In cases where there is an extended plinth to a dwelling, the unit on the opposite side of the street should have a plinth that recedes to maintain the minimum street width.

### SUPPORTS - lower level

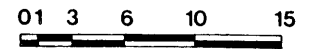
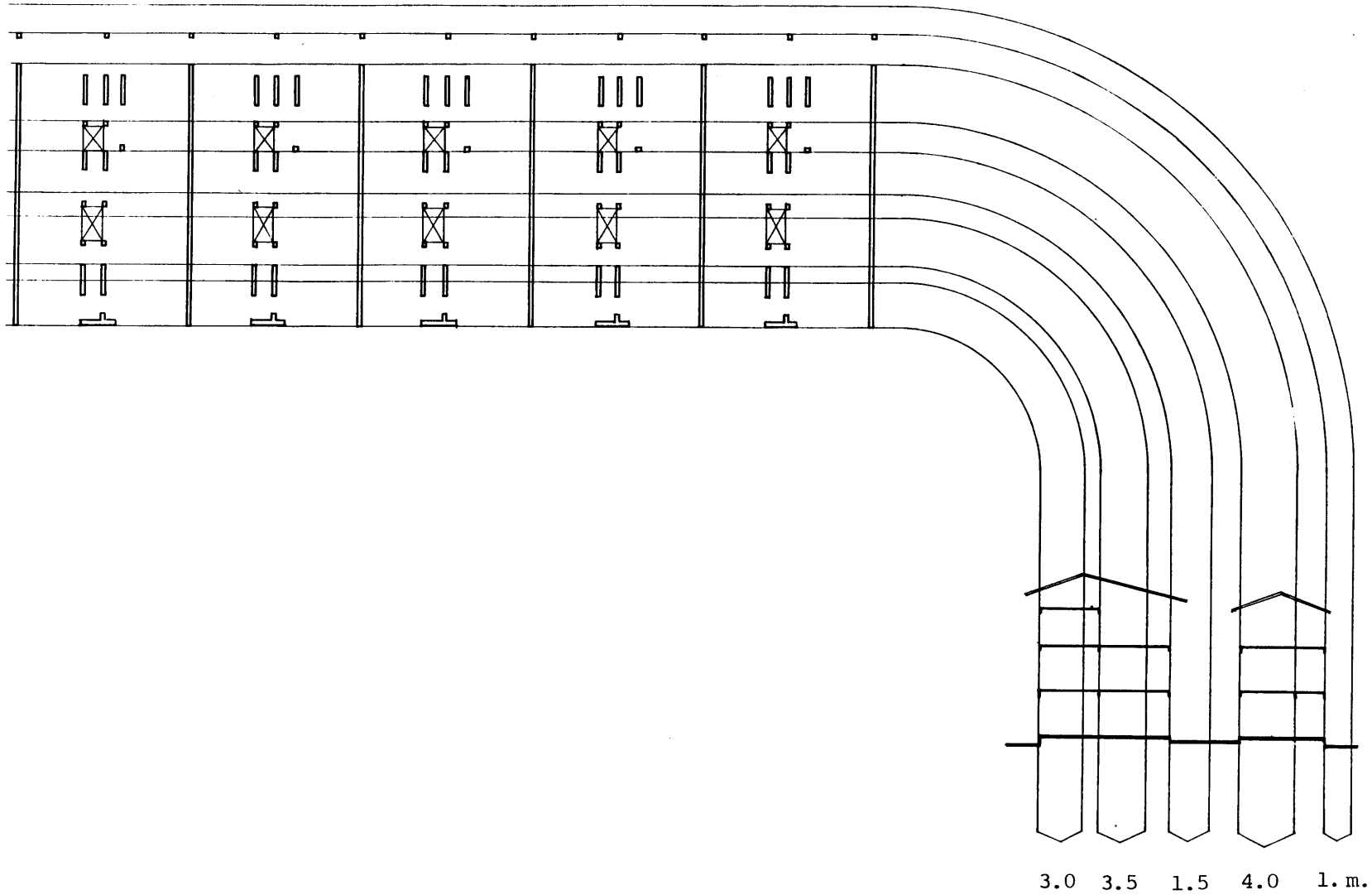

### SUPPORTS - upper level

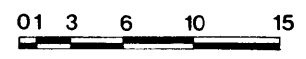
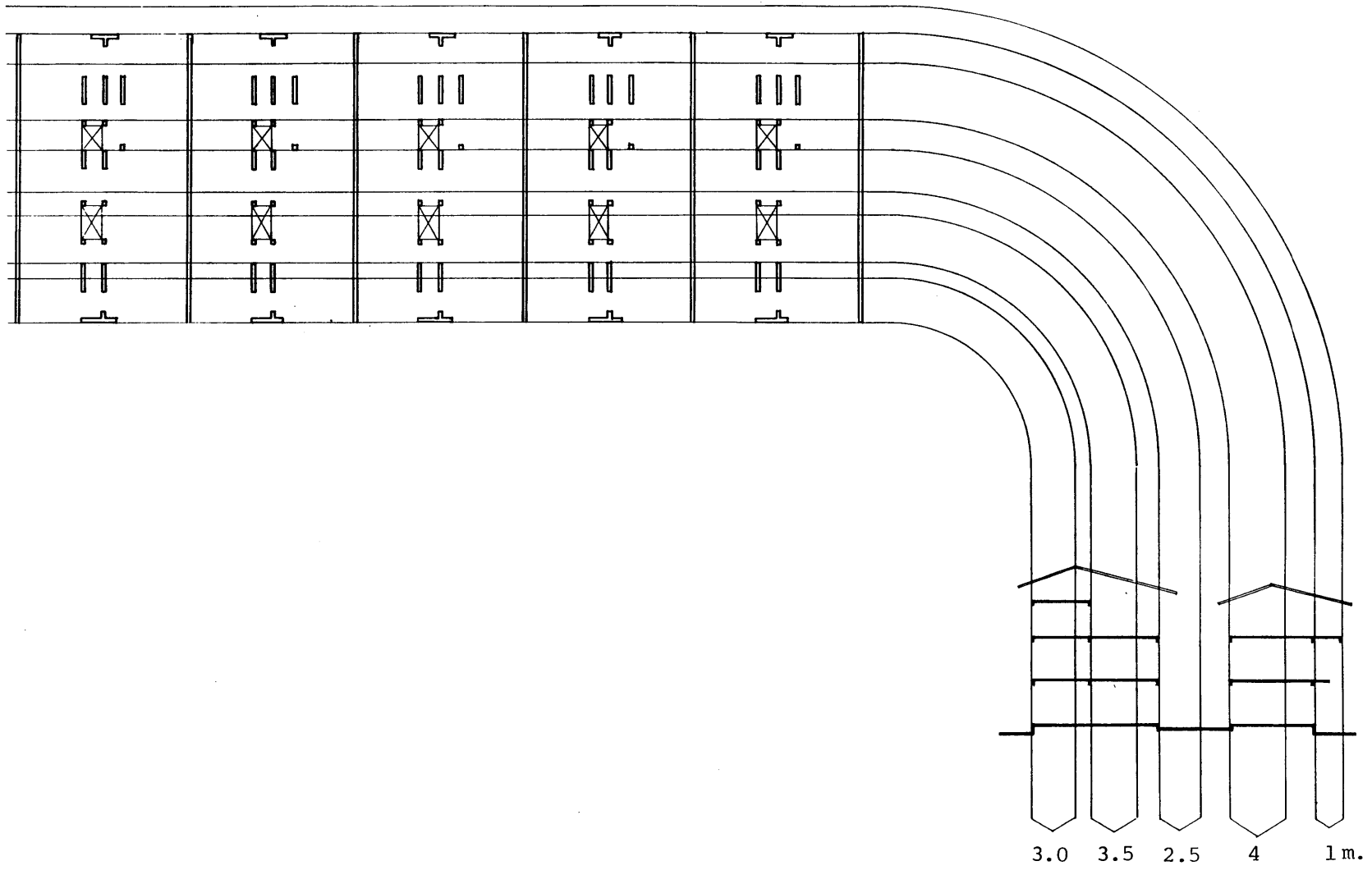



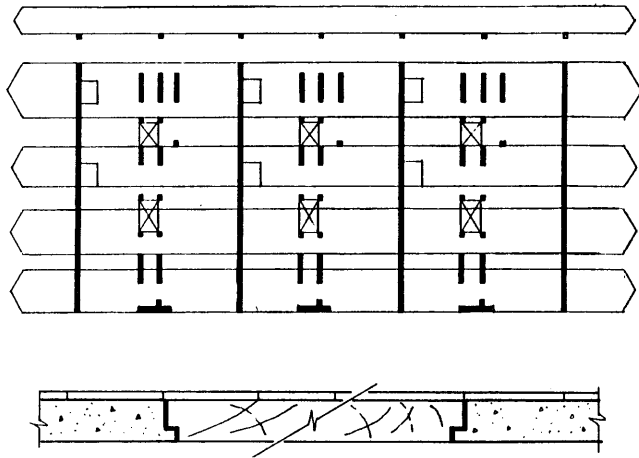

The shaded areas show the staircase cutouts provided. When not in use, a wooden infill would be used to close the cavity, such that it be used at a later date if necessary.

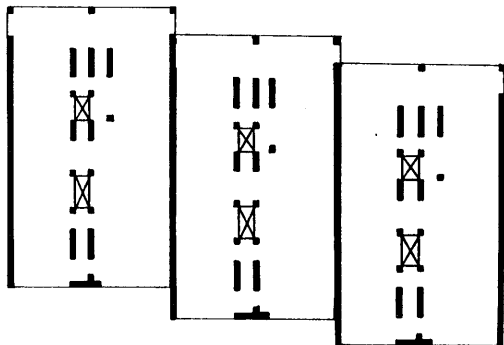

Units could be staggered only along the continuous walls, dividing two units.

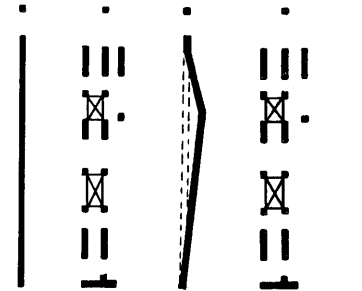

The straight wall allows for distortion in the case where there is the need for an insertion in an existing situation.

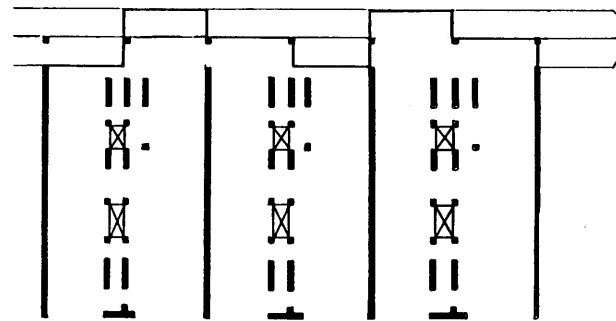

The zone provides for possible extension of the raised plinth, so as to create an interesting non-linear street, keeping in character with the prevailing conditions.

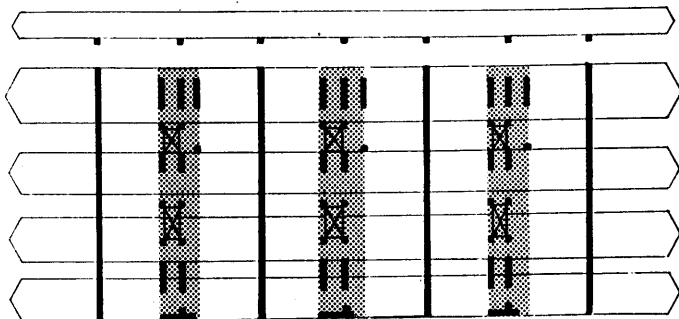

The shaded area demarcates the service sector of the support structure, which would be used by the units adjoining it.

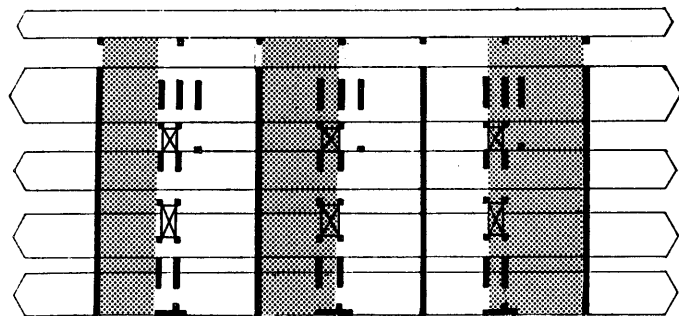

The shaded area show the limits of the basic units possible within the supports.

80 sq.mts. 110 sq.mts. 140 sq.mts.

**ISOMETRIC VIEW**

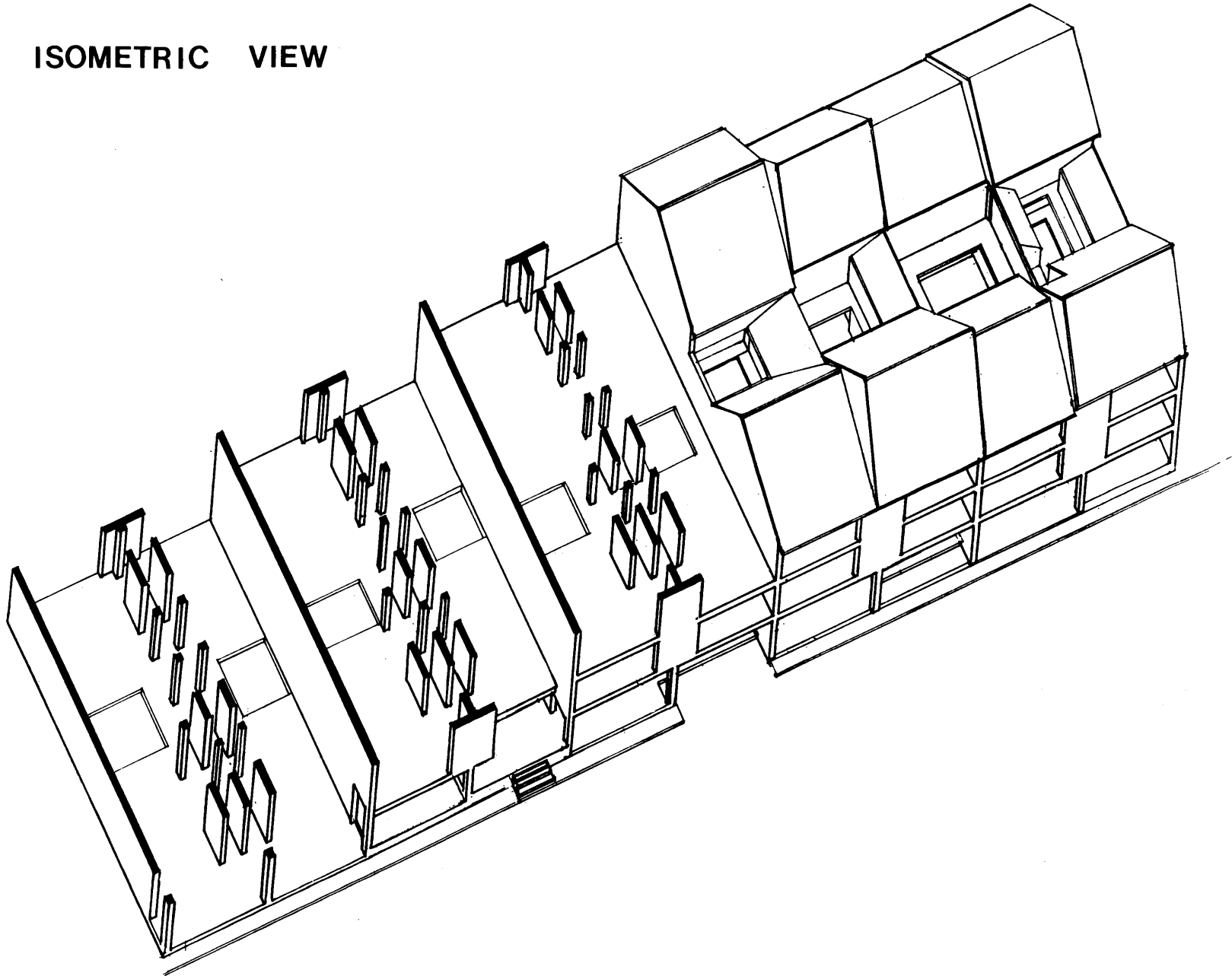

## SECTIONAL OPTIONS

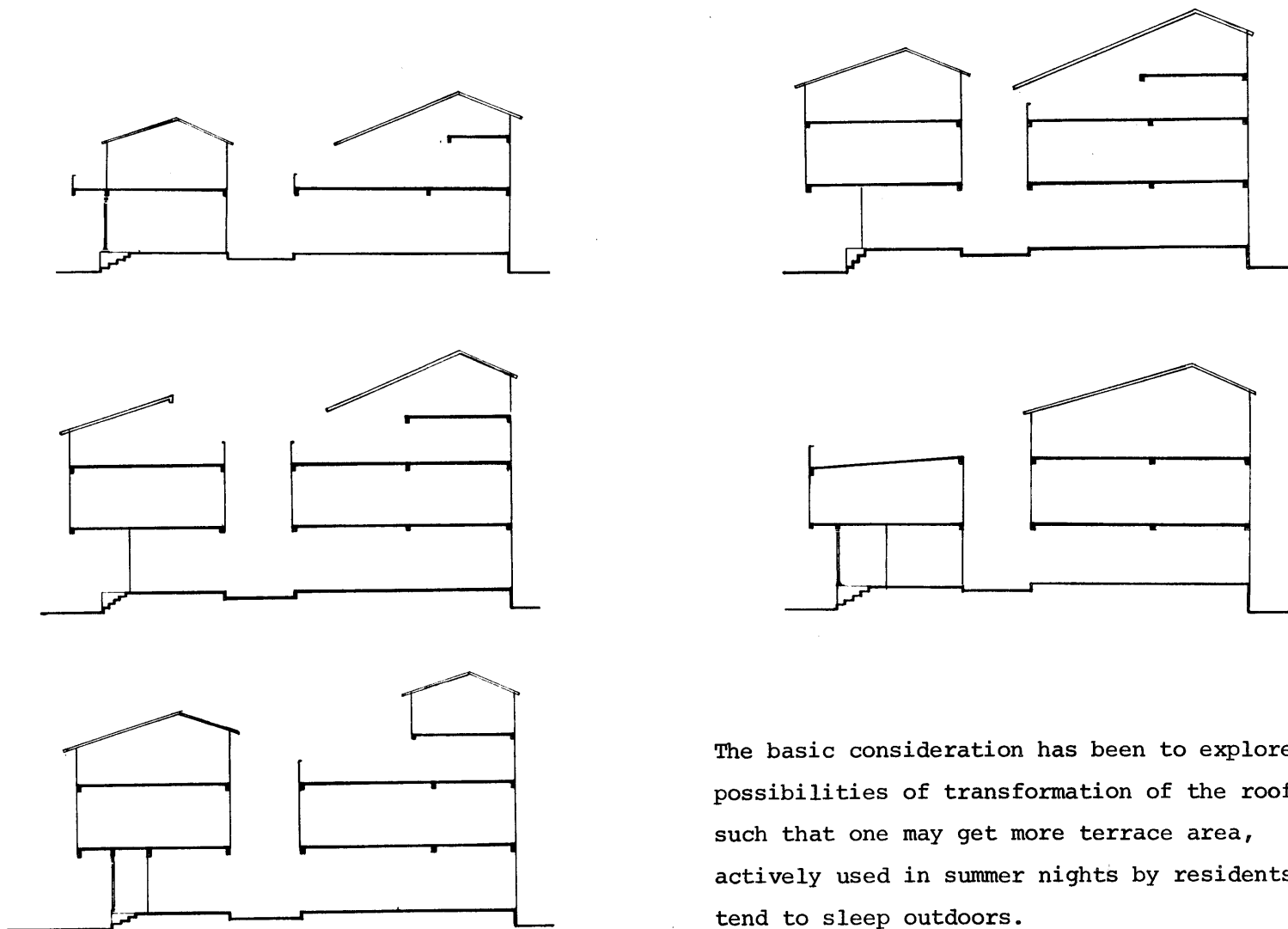

The basic consideration has been to explore the possibilities of transformation of the roof, such that one may get more terrace area, actively used in summer nights by residents who tend to sleep outdoors.

# SECTOR ANALYSIS

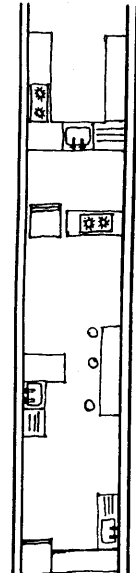
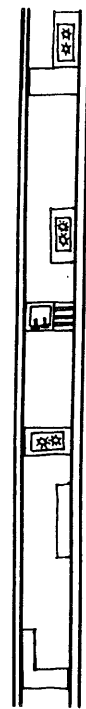
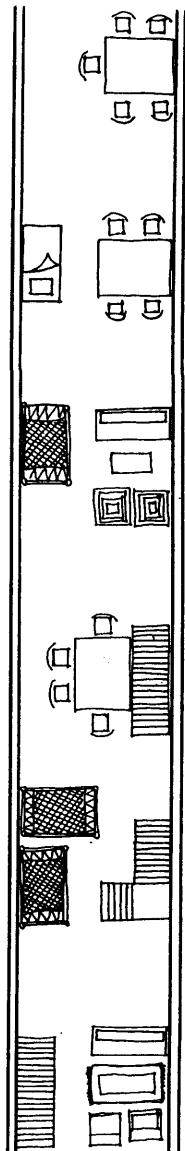
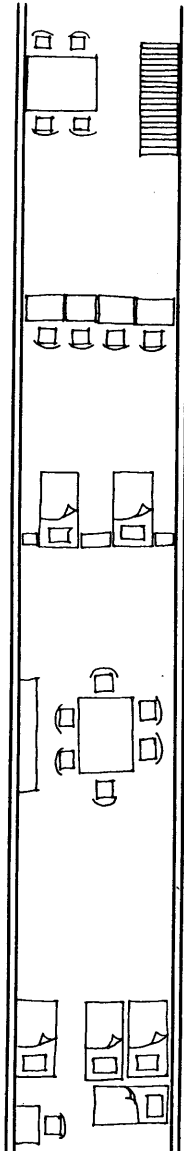
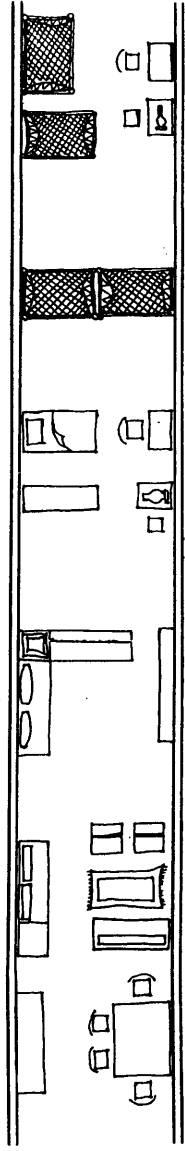
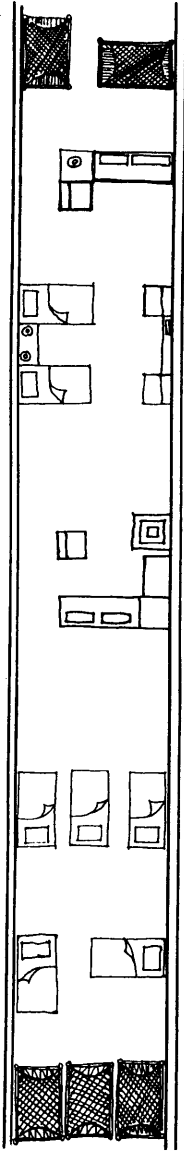

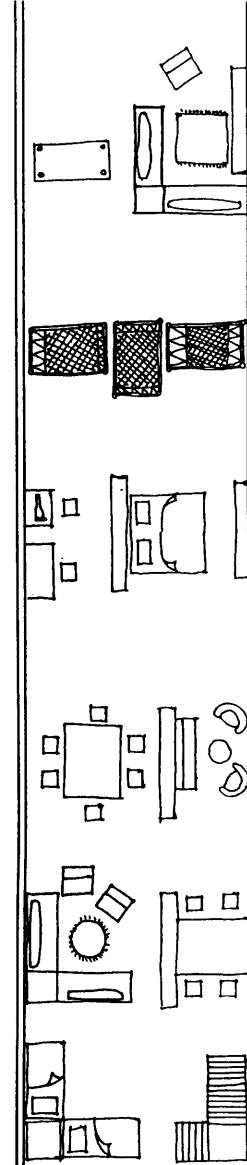
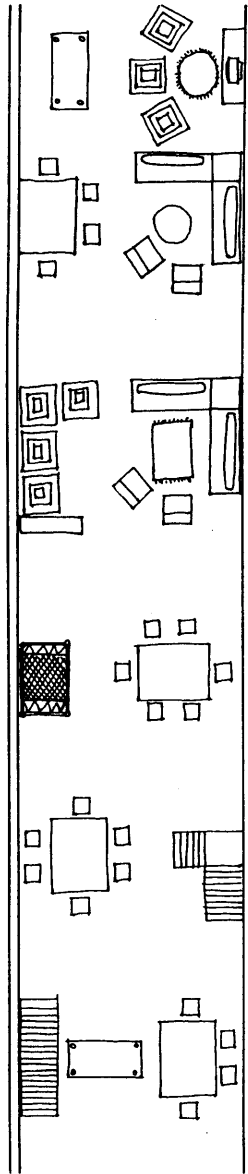
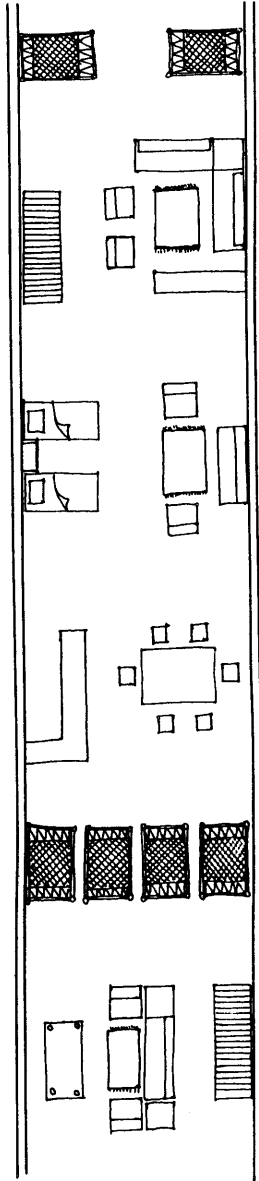
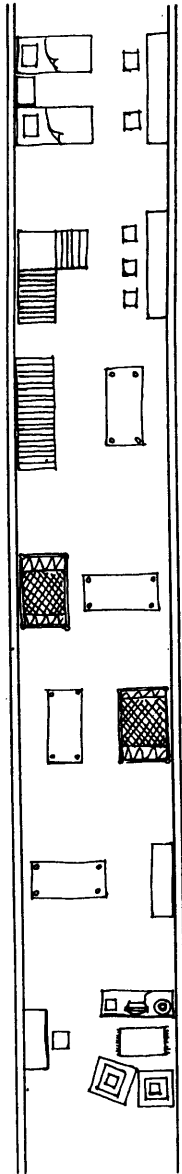

# ZONE ANALYSIS

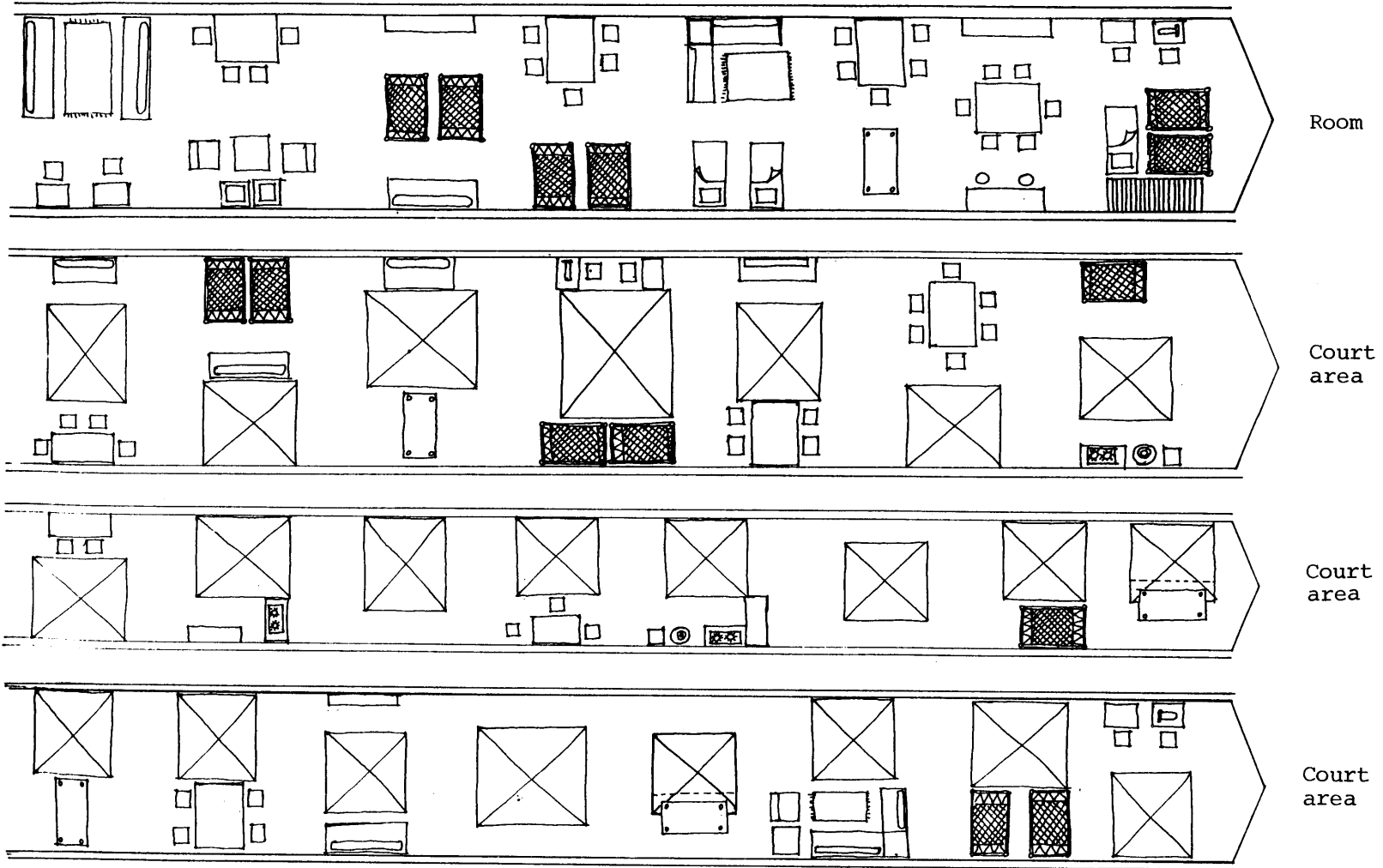

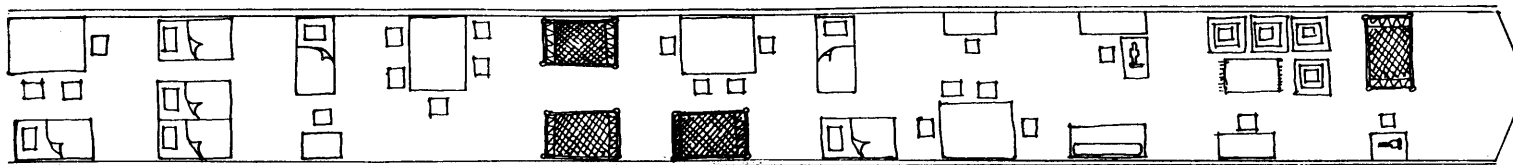

Room

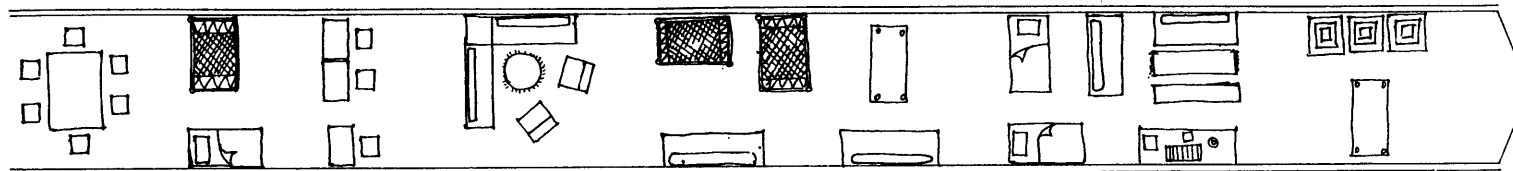

Room

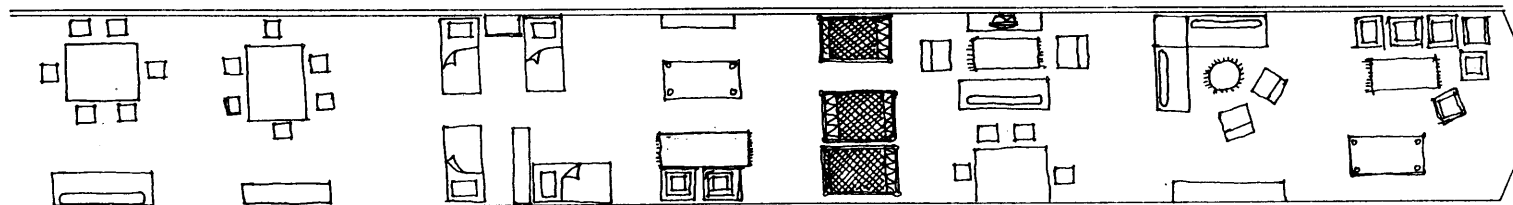

Room

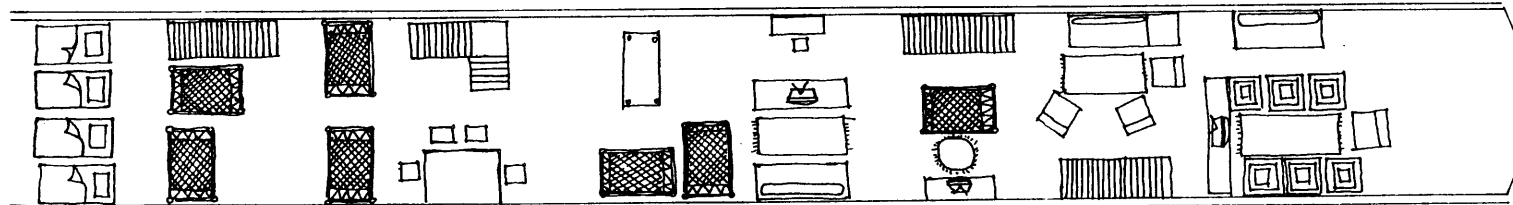

Room

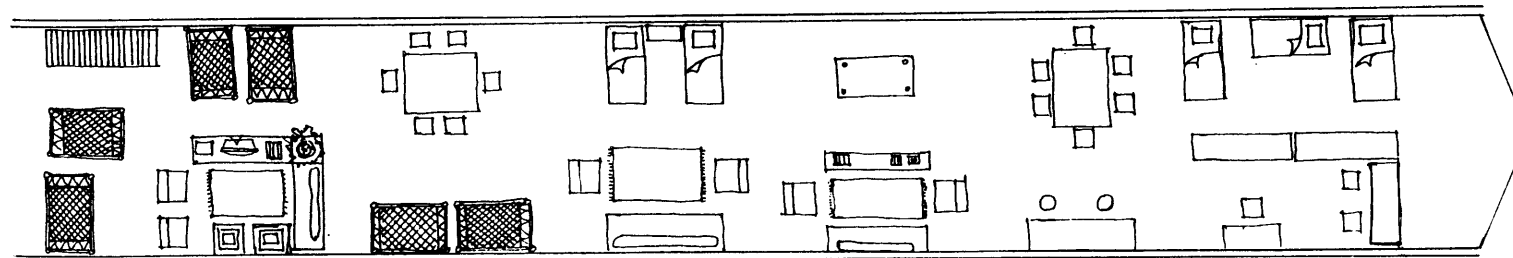

Room



# RANGE OF SPACES

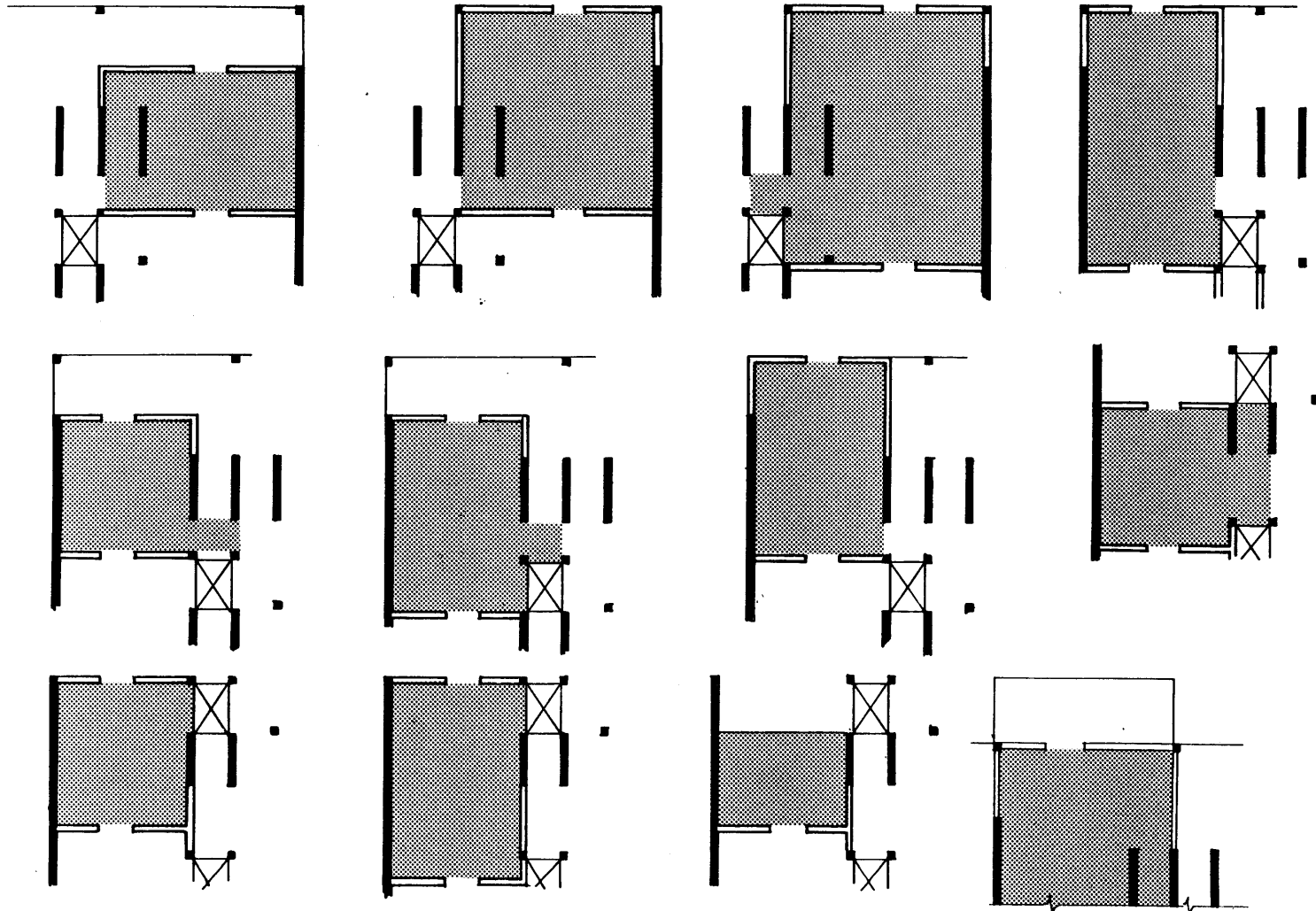

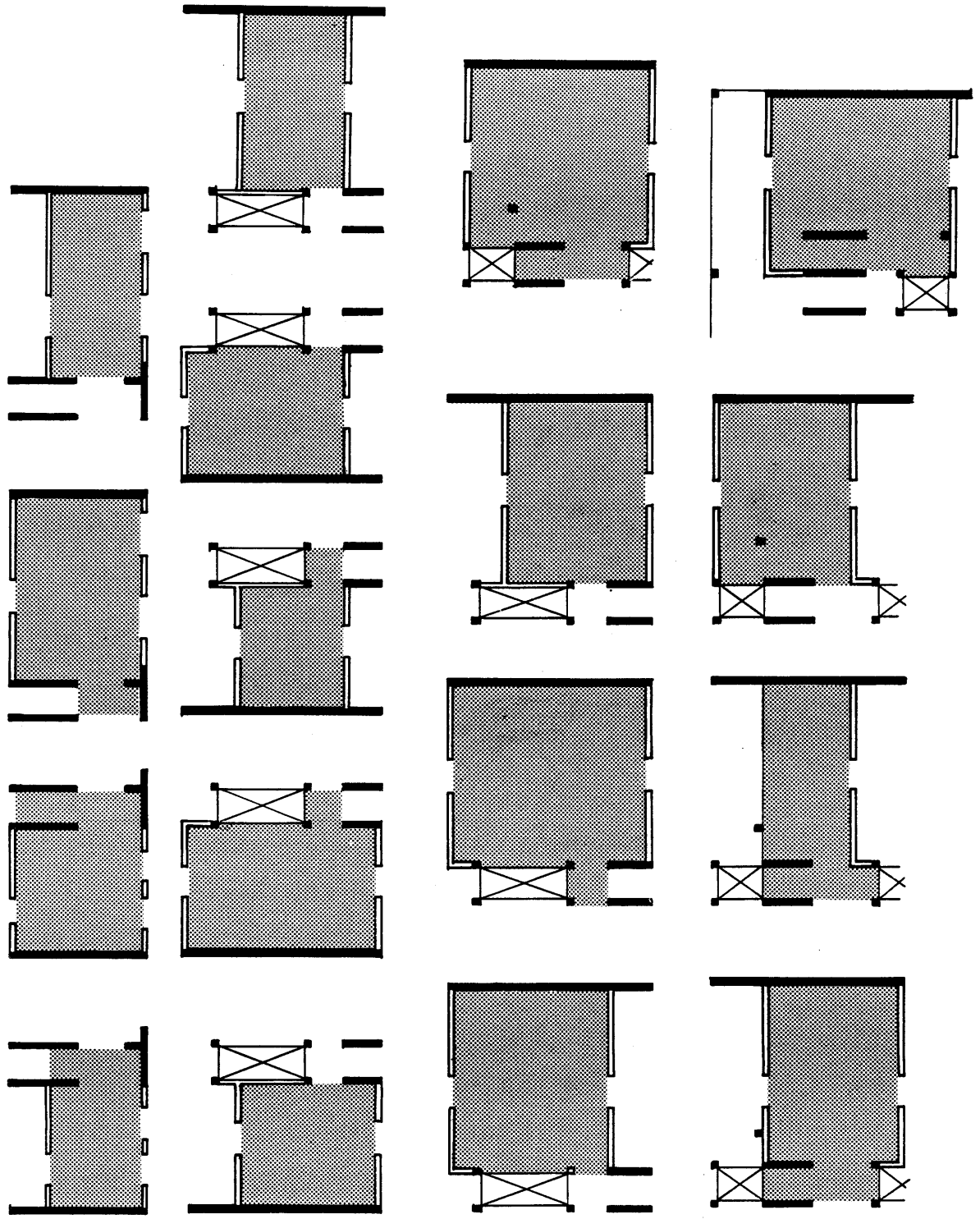

# CAPACITY OF AREAS

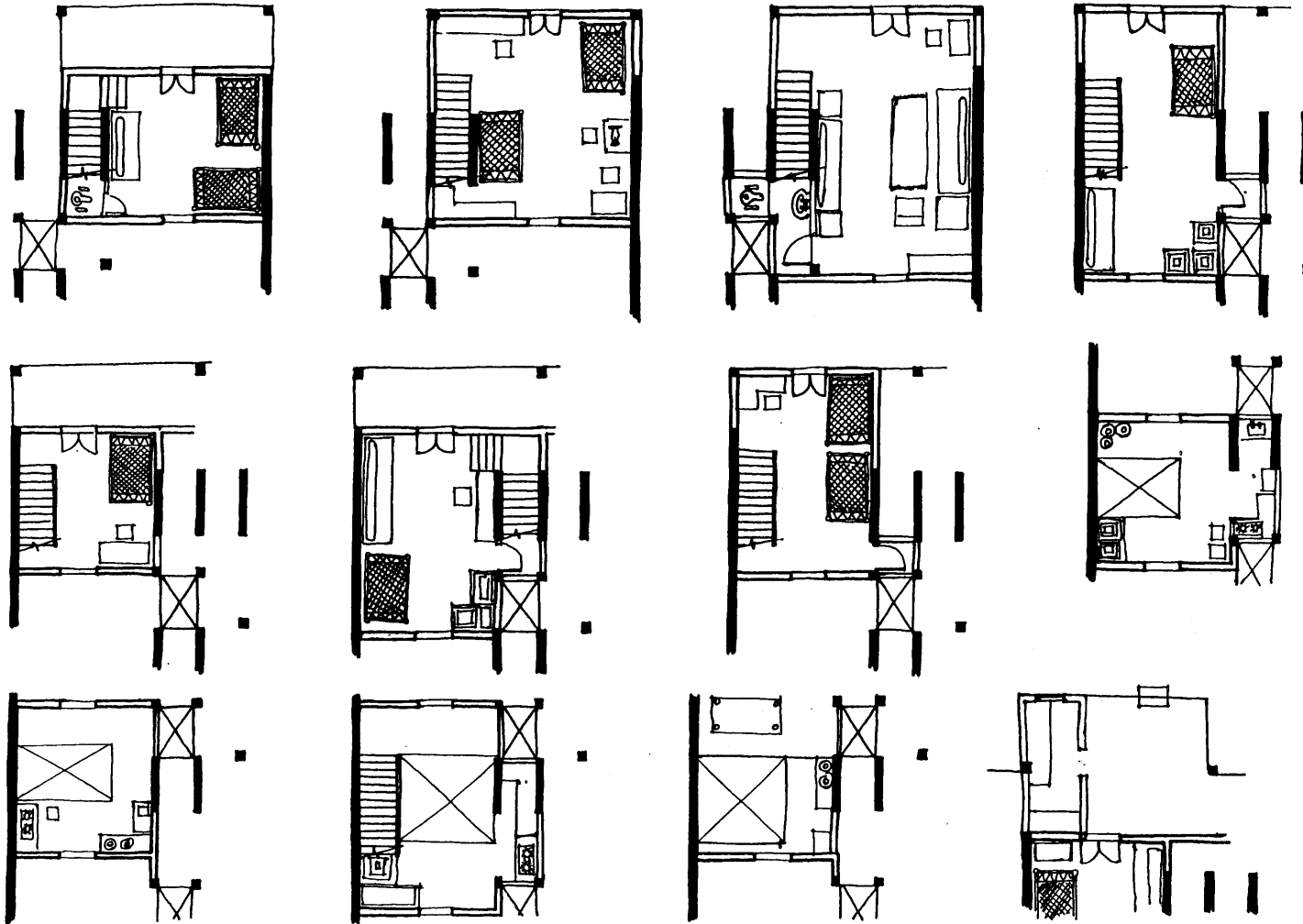

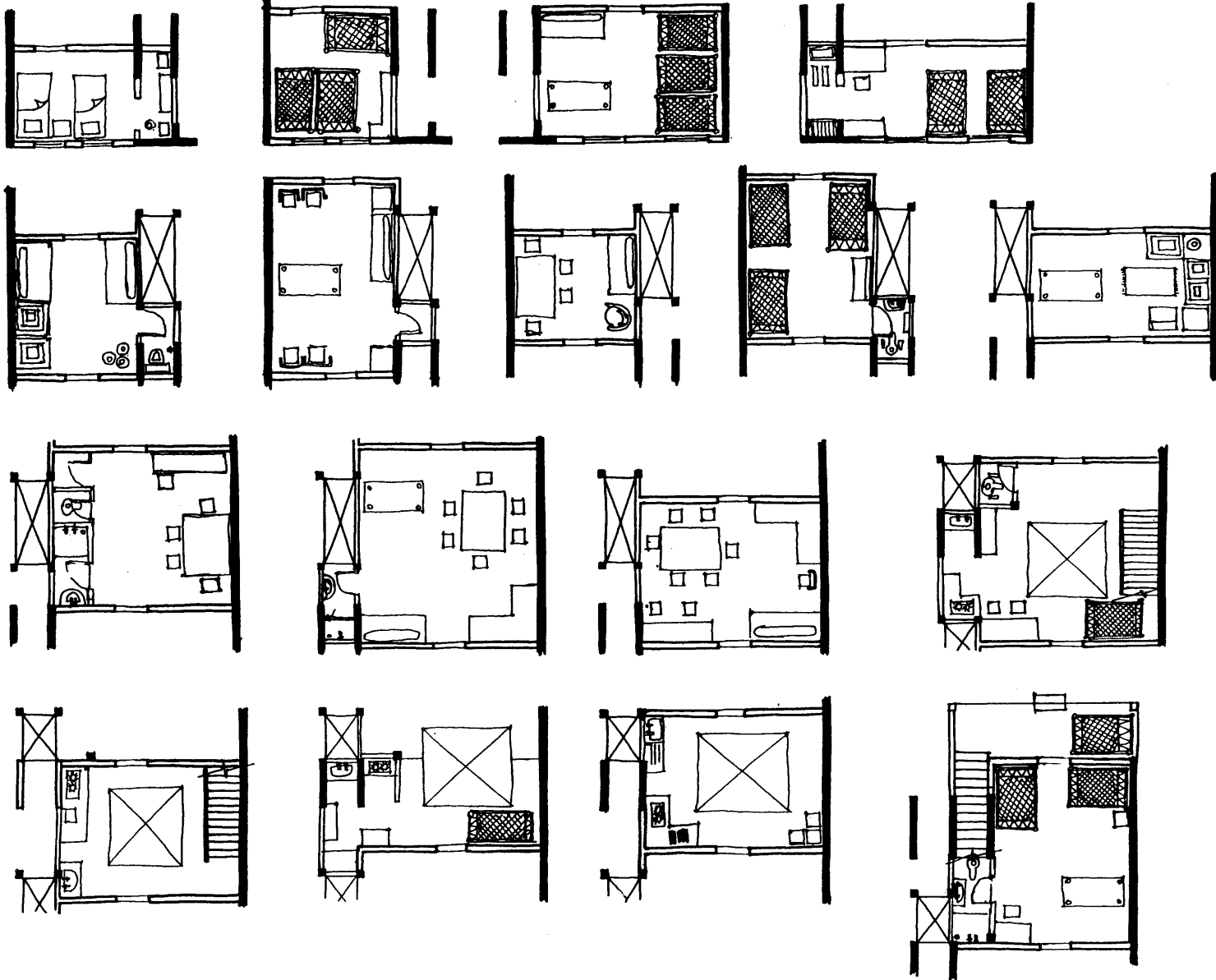

## STAIRCASE VARIATIONS

The staircase areas have been designed such that they are capable of change, which would serve different purposes when required by the inhabitants of the dwelling. The underlying aim of the design has been to safeguard the territorial limits of the residents.

Case 1: The access to the room on the second storey would be through the entrance room and would be used by the immediate family or by relatives, in the case of the extended family.

Case 2: If the room on the second storey is to be let out to an outsider, an external access could be provided, which would tend to restrict an encroachment on the landlord's territory.

Case 3: This case allows for the third storey to be let out, hence an external entrance, and the second storey to be used by the landlord, using an internal access.

Case 4: As is observed, whole floors are being

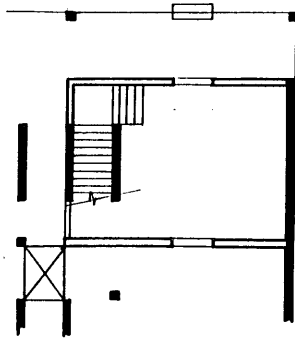

1.

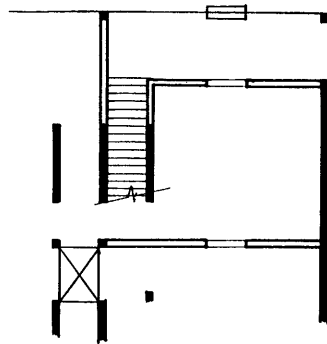

2.

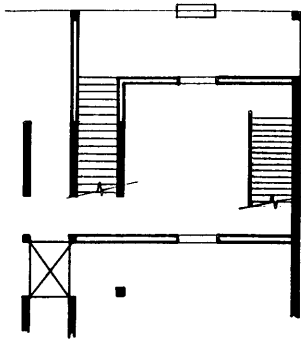

3.

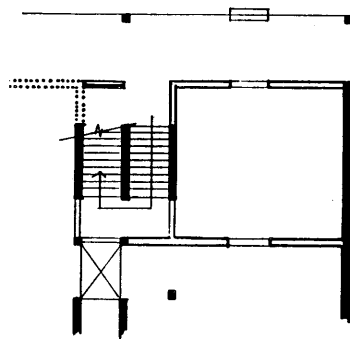

4.

let out to individual families, thus converting a row house into an apartment dwelling. In view of this, a dog-legged staircase could be erected between the three parallel support walls, which could service the apartment/s on the upper levels .

Thus by providing a variation in the type of access ways to the upper storeys, one can control the probable change in the territorial organization that could be a result of the changing social structure.

# TRANSFORMATIONS

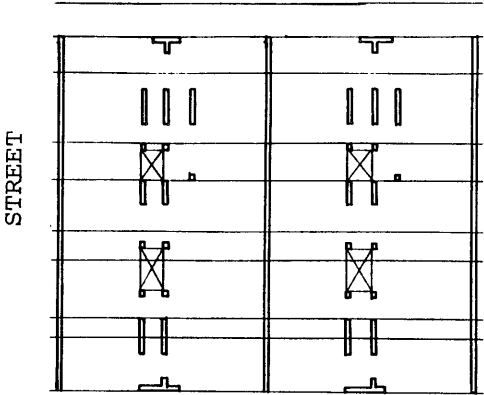
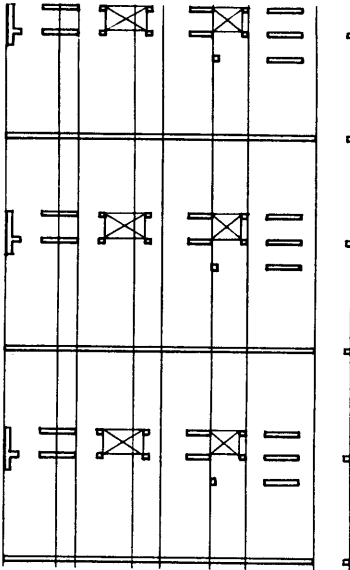
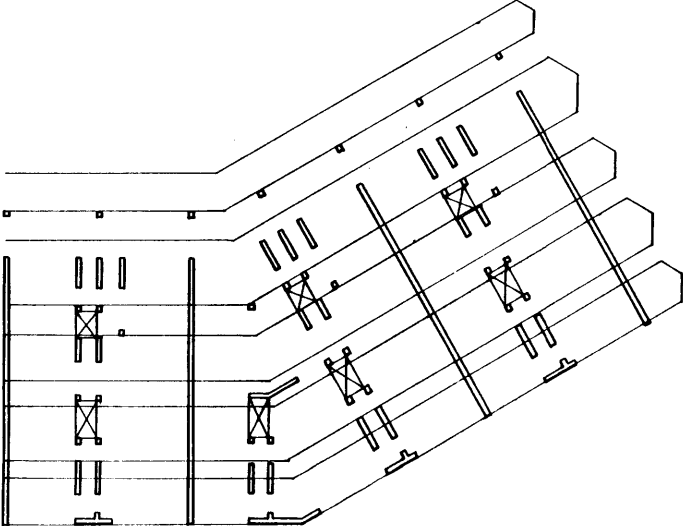
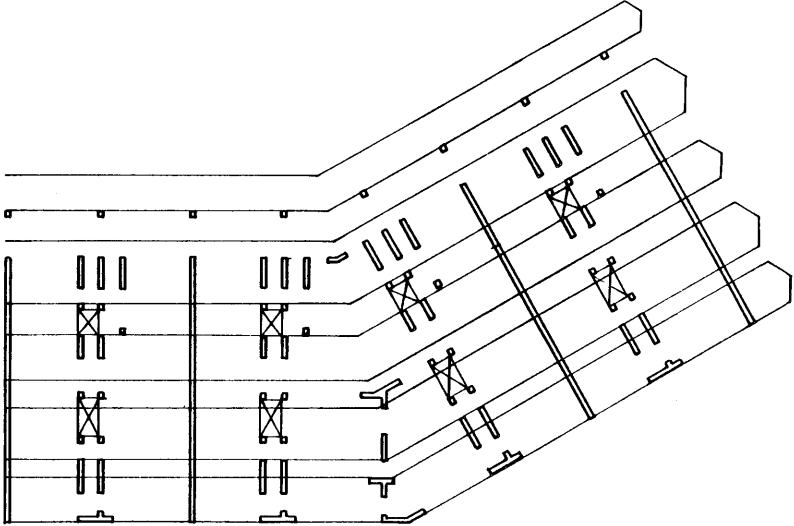
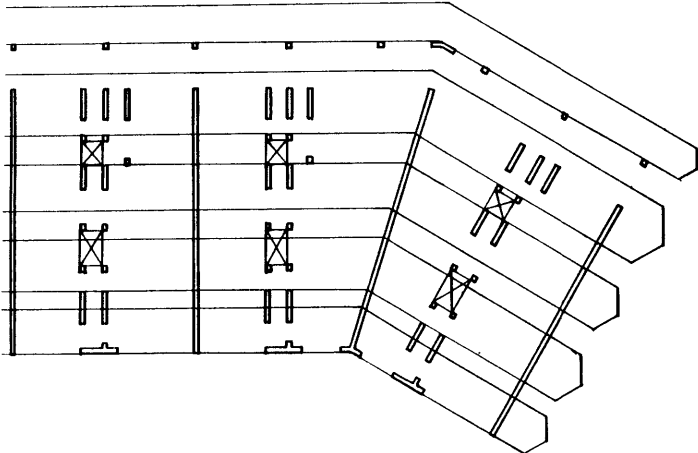

STREET

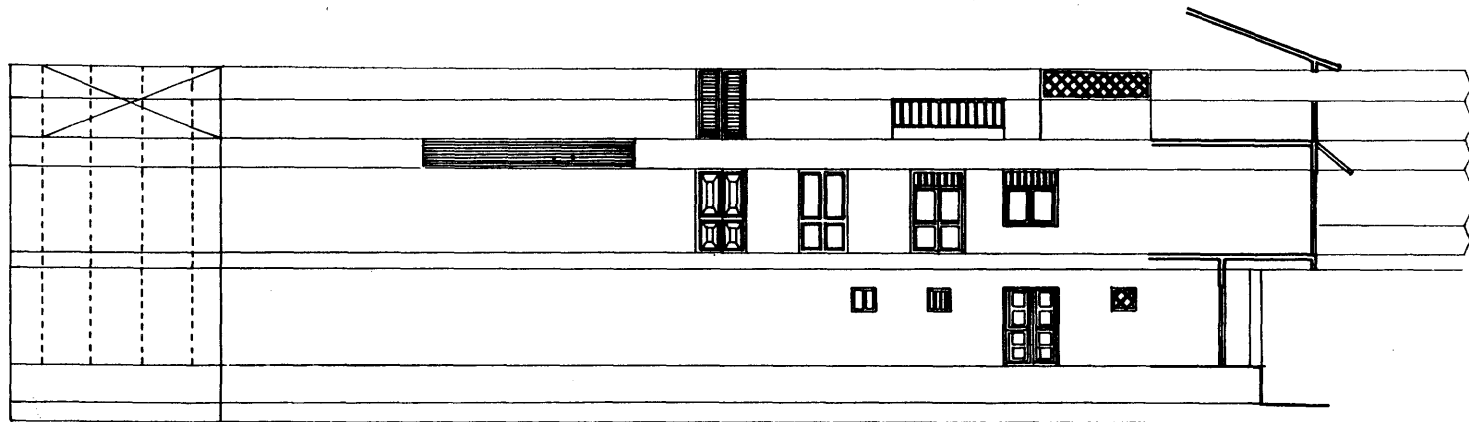
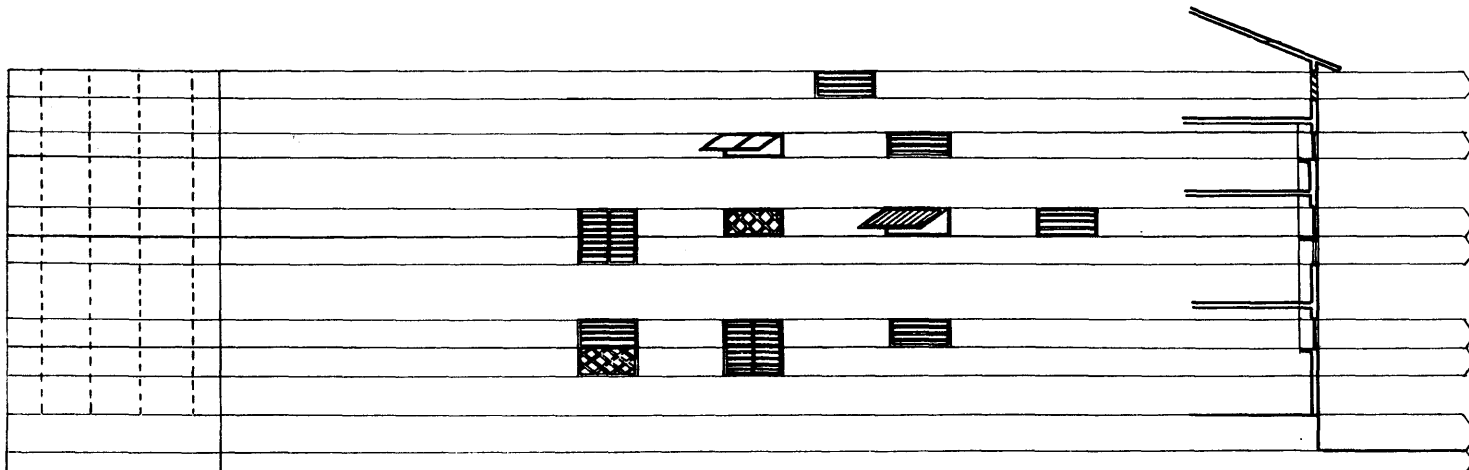
**FACADE ELEMENTS****FRONT FACADE****REAR FACADE**



# APPLICATION ON SITE

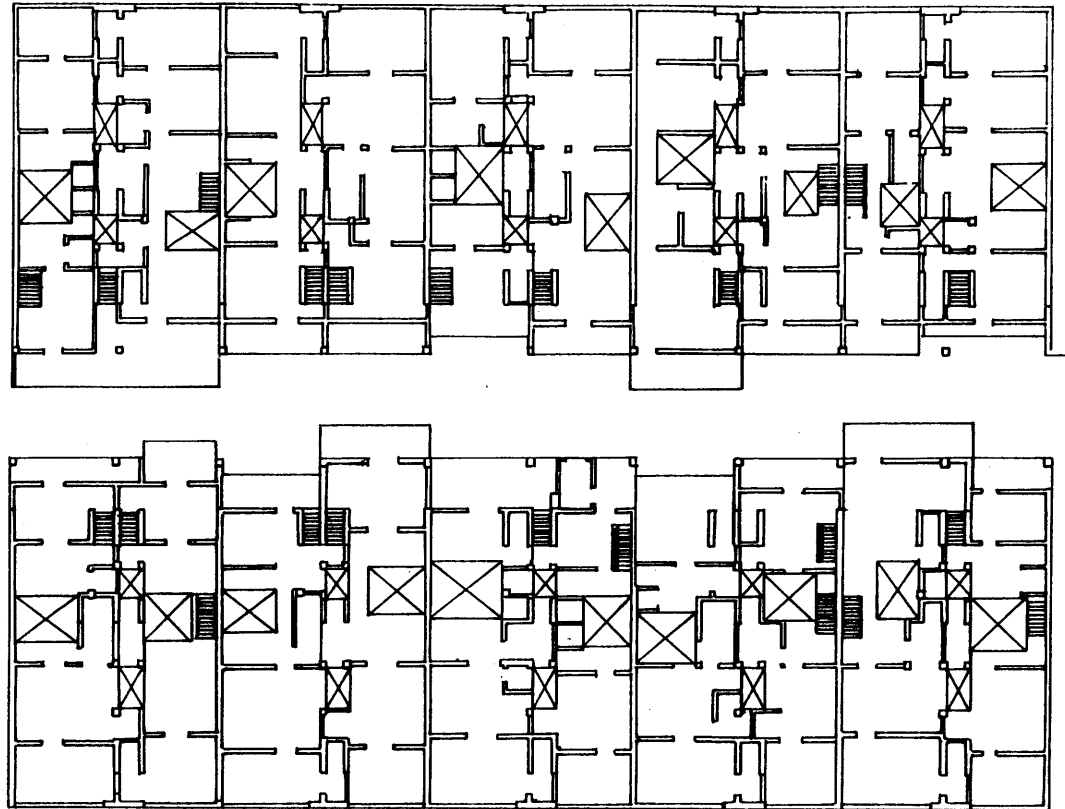

EXTENSION OF THE PLINTH AS A DETERMINENT OF  
THE STREET CHARACTER

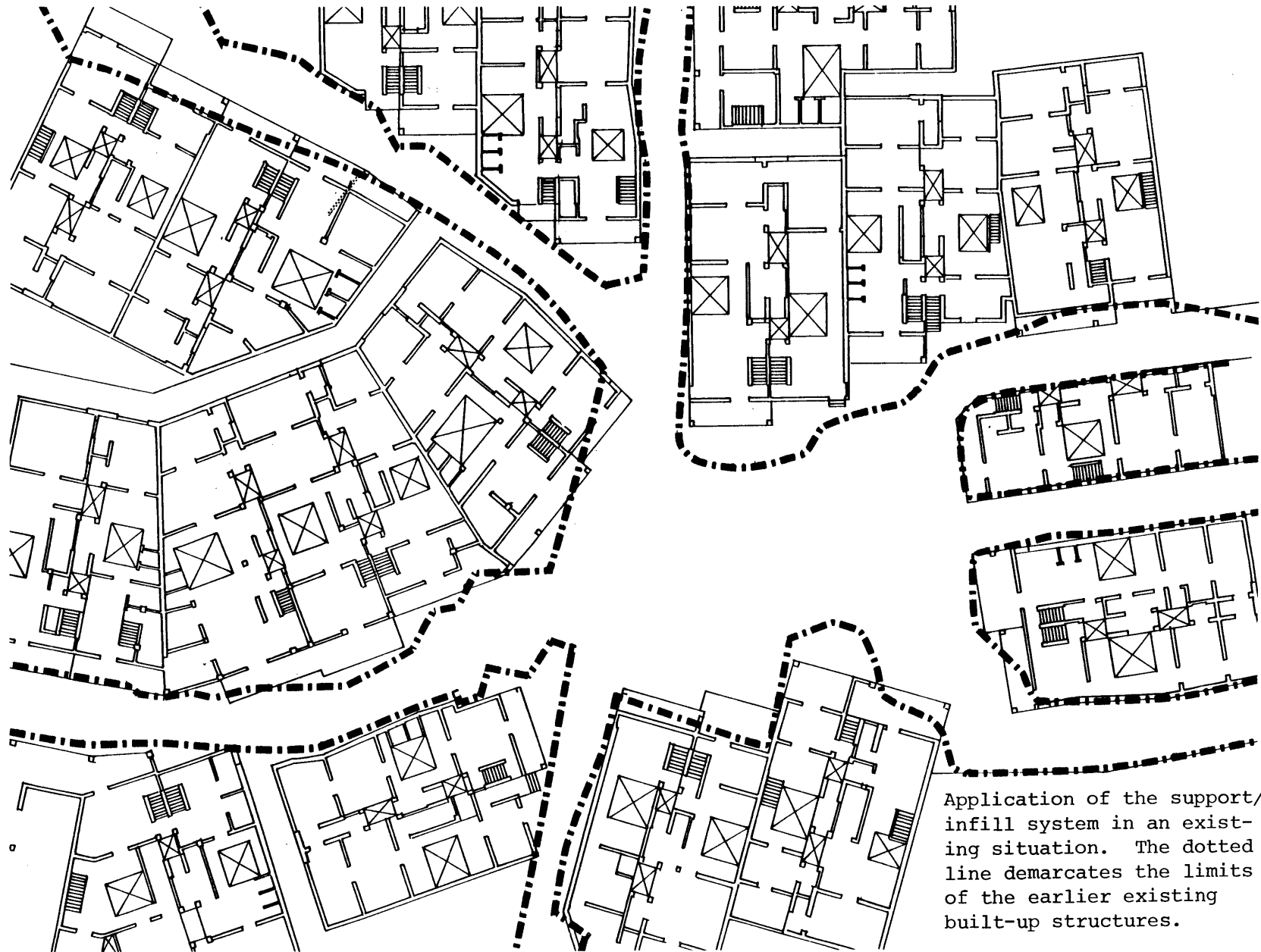

Application of the support/infill system in an existing situation. The dotted line demarcates the limits of the earlier existing built-up structures.

## CONCLUDING REMARKS

Having gone through the process of working with the Support/Infill Methodology, I have begun to understand more thoroughly, the importance of such a system and its implications in design. Besides the fact that it allows for a certain range of variation of built form, it has the capability of application in varied contexts. This is possible in a manner that it does not disregard , but on the contrary is capable of incorporating within it, the old traditional norms of building.

Most housing presently being carried out in India is designed towards a final end product which does not seem suitable for the situation. This is because there is little mobility of people with respect to housing and a family generally tends to live in the same dwelling over a period of time, after which it is passed

down the generations. Due to the changing needs in time, the dwelling does not conform to the needs of its inhabitants and the latter is left to making compromises in an attempt to adapt to a changing situation. It is therefore evident that usually it is the inhabitant that has to adapt to the dwelling and not vice versa, as should be the case. Thus what would sometimes seem as a viable solution at the time of design is indeed a disaster, when in use over a long duration. So as to counteract this problem, designers should take into account possibilities of variations in the design such that the dwelling transforms from a static inanimate object, to one capable of change and growth as an additive process.

The SAR Methodology has been developed in this direction and these issues have been addressed

through the course of writing this thesis. Its application in the thesis has not been at a level of detail of building as it has been the intention only to explore the versatility of the system by its subsequent application in the Indian context. It is nevertheless hoped that in the future, should one intervene in this context, the study prove useful in a manner that it be elaborated upon to a level of actual construction.

**BIBLIOGRAPHY**

- Acharya, P.K. Architecture of Mansara, vol 4/5, published by Oriental Books Reprint Corporation, New Delhi, 1980.
- Akbar, Jamel A. Support for Courtyard Houses Riyad, Saudi Arabia, Thesis, MIT, 1981.
- Chavda, Alka Vidyadhar Rural/Urban Dwelling Environments: Gujarat State, Ahmedabad, Thesis, MIT, 1975.
- Dekker - ARO Consulting Supports can be costly. MIT
- Gami, Bharat Urban Settlements in Intermediate Cities, Gujarat State, India, Thesis, MIT, 1976.
- Habraken , N.John Transformation of a Site, Awtar Press, 1982.
- Supports - An alternative for mass housing, Architecture Press, London and Preger, New York, 1971.
- Variations - The systematic design of supports, MIT Laboratory of Architecture and Planning, 1976.

- Habraken, N.John.,Liu, Lu. Thematic Design, Class Notes, Fall '82. MIT.  
Akbar, Jamel A.
- Patel, Nimesh. Urban Dwelling Environments: Ahmedabad, India. Thesis MIT 1972.
- Sanyal, Shubhankar Towards a Design Methodology - A case of Chawls in Bombay. Thesis. MIT, 1983.
- Shah, Parul A Study of Change - Its Comprehension and the Evidence of Change in a Dwelling Form. Thesis, C.E.P.T., School of Architecture, 1977.
- Shetty, Rajmohan A Study of the Traditional Residential Quarters in Ahmedabad as an Expression of Dominant Social and Cultural Forces. Term Paper, MIT,1983
- Singh, Ravindra Traditional Urban Indian Neighbourhoods, Ahmedabad. Thesis,C.E.P.T., School of Architecture, 1974.