

MECHANICAL DESIGN OF COLLIMATORS FOR THE ILC*

B.D. Fell[†], D.Angal-Kalinin, S.C. Appleton, N. Bliss, J-L.Fernandez-Hernando,
 F. Jackson, O.B. Malyshev, STFC, Daresbury Lab., UK
 N.K.Watson, Birmingham Univ., UK
 J.D.A. Smith, Lancaster Univ., UK
 G.E. Ellwood, R.J.S. Greenhalgh, STFC, Rutherford-Appleton Lab., UK

Abstract

Much attention has been paid to the optimisation of the geometry and material of collimators in the ILC to mitigate the effects of both short-range transverse wakefields and errant beam impacts. We discuss the competing demands imposed by realistic engineering constraints and present a preliminary engineering design for adjustable jaw spoilers for the ILC.

INTRODUCTION

Collimators are essential to remove beam halo and avoid beam losses in the vicinity of the interaction point that could lead to unacceptable backgrounds for particle detectors. In the case of the International Linear Collider (ILC), the collimation system consists of a series of adjustable jaw spoilers and absorbers, and fixed aperture protection collimators.

Of the 14 types of absorber, spoiler or protection collimator included in the ILC Beam Delivery System (BDS), six distinct devices with adjustable apertures are identified. These are shown in Table 1, together with representative values for their key parameters.

Table 1: ILC BDS adjustable jaw collimators

Device	Absorber (cm) material	Power (kW)	Full gap (mm) min, max
SPEX	3.6, Ti	0.01	1, 10
SP1–5	2.1, Ti	0.01	1, 10
AB2–5	42.9, Cu	1–20	0, 10
ABE	10.5, W	0.1	0, 10
MSK1	10.5, W	0.01	NA
MSK2	10.5, W	0.01	NA

The spoilers present a particular problem having the largest sensitivity to wakefields and we therefore concentrate on developing a preliminary design that, although having many features which are applicable to other adjustable jaw collimators, is specific to devices SP1–5.

* Work supported by the EC under the FP6 Research Infrastructure Action - Structuring the European Research Area EUROTeV DS Project Contract no.011899 RIDS and STFC

[†] B.D.Fell@dl.ac.uk

REQUIREMENTS FOR ILC SPOILERS

The jaws of the spoilers must be able to withstand two (one) bunch impacts at 250 (500) GeV beam energy following asynchronous beam aborts without causing excessive increases in emittance due primarily to short range transverse wakefields. The optimisation of spoiler jaws is ongoing with simulations [1] and recently completed experimental tests for wakefields [2], complemented by initial experimental tests of material damage [3].

The baseline design for the SP2 spoiler jaws in the ILC Reference Design Report (RDR) [4] is a Ti spoiler block 21mm in longitudinal extent, with Be tapers up- and downstream to reduce wakefield effects and prevent significant electromagnetic showering owing to its large radiation length. In this design, we assume that:

- spoiler jaws will be rectangular in transverse section, hence transition flare from circular beam pipe;
- spoilers will be peripherally cooled;
- occasional access will be necessary to replace jaws after beam damage;
- spoilers will be required to open to a full gap of 20mm;
- overall design will be parametric to allow for both evolution in jaw design and extension to devices other than SP2.

KNOWN CONSTRAINTS

The location of the spoilers close to sensitive machine elements limits their maximum length, therefore designs of the jaws which are shorter than that achieved by a single, constant angle taper are desirable. It is essential that integration of the jaws into the vessel does not lead to an radio frequency (RF) cavity-like geometry, and this is the subject of a related study [5].

Although the design goal is to have passive survival of spoilers up to two full charge bunch impacts at 250 GeV beam energy, the integrity of both the surface and bulk of the jaws would have to be validated after potentially damaging incidents. The current design does not include any scheme for such in situ study, leaving this as an option to be studied in the future.

DESIGN APPROACH

There are aspects of the design which are not fully specified, most notably the final structure of the jaws. A baseline

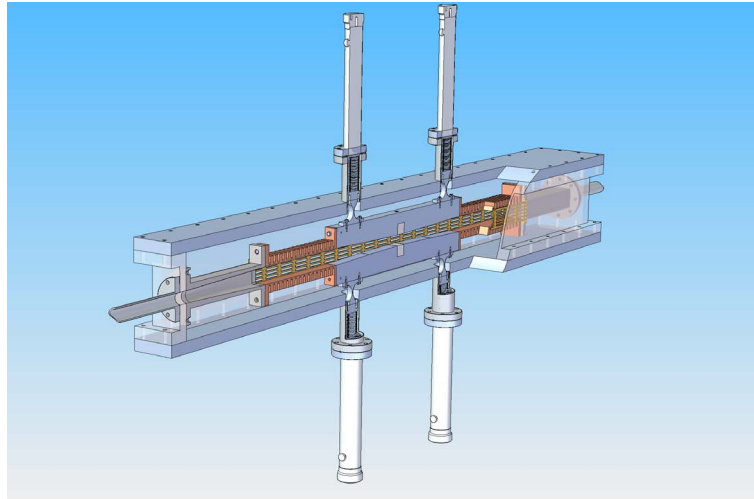

Figure 1: Overview of preliminary, baseline spoiler candidate design.

design was generated, shown in Figure 1, which accommodates most of the desirable features and we have considered three options on this to explore ways of reducing length.

Motion Control

The jaw movement is via generic type, motorised linear actuators which operate through vacuum bellows. A specification is required to permit bi-directional repeatability of no more than $10\mu\text{m}$, with resolution at the $1\mu\text{m}$ level. The final design shall ensure that changes in air pressure of 5% should not produce changes in position above the repeatability. Consequently, chamber lids should also be of appropriate thickness (or ribbed) to ensure mechanical stiffness greater consistent with this.

Advantages of this design are that encoders and motors can be placed well out of the plane of maximum radiation environment and can be further protected by shielding external to the vacuum environment, as well as being easily accessible for maintenance and/or replacement.

An external linear encoder coupled to the direct motion of the drive should be fitted in addition to the motor encoder to produce an absolute reference for the motion position. It is also possible that a radiation protected and/or hardened encoder device could be fitted inside the ultra high vacuum environment to encode the motion closer to the actual spoiler position, which would also provide redundancy in the measurement.

Externally, precision limit switches and possibly a laser level could also be fitted to monitor angular difference as a function of differential motion between up- and downstream actuators. Note that the design has flexural pivot points to allow a certain degree of differential motion between actuators so that the collimators can be changed in pitch angle with respect to the beam axis.

Cooling

As mentioned above, it is assumed that spoilers will be peripherally cooled and therefore no cooling routes are shown. Although it is envisaged that the spoiler will stop 10W of power in standard operation, the collimator blocks, flexibles and flared aperture downstream of the spoiler could potentially absorb kW via e^\pm or photons. Small bore stainless steel (or oxygen free high conductivity Cu) piping should be brazed to these components. The exact sizing, distribution and pattern of the cooling tubes should be assessed after studies of radiation deposition analysis, using codes such as FLUKA, followed by finite element modelling of the consequent thermo-mechanical stress.

Side Walls

These must satisfy two competing demands, providing good conductivity (low impedance) while allowing sufficient pumping capability, as collimated beam particles and SR photons will cause gas desorption from the jaws, more so at smaller apertures. The baseline design includes Cu side walls which have pumping slots with a 10:1 aspect ratio (parallel to the beam axis), and transparency (fraction of side wall area occupied by holes) of approximately 40%.

DESIGN OPTIONS

Option 1: Baseline

The default concept includes a 20 mm diameter circular cross-section beam pipe flaring into a $30(\text{h}) \times 40(\text{w})$ rectangular section over a length of 200mm, followed by a tapered collimator consisting of two different angles, the shallowest closest to the beam. See Figure 2 for detailed view of this; Figures 3 and 4 illustrate the flared transition.

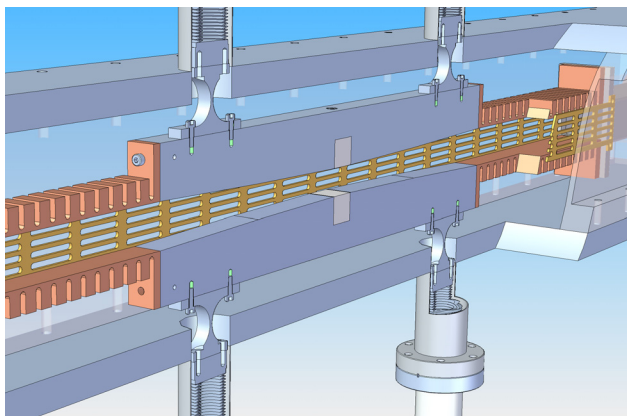

Figure 2: Detailed isometric view of baseline spoiler candidate design.

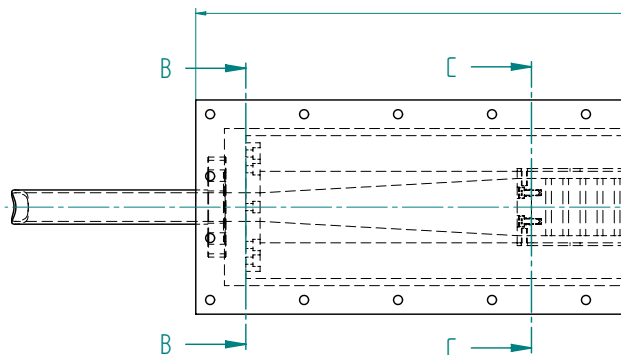

Figure 3: Plan view of transition flare between beam pipe and tapered collimator jaws, showing cross-section planes B-B and C-C

Option 2: Minimal Taper Angle

This differs from the baseline in that the two-step taper is replaced by a constant 19mrad tapered longitudinal profile (as in the ILC RDR). This reduces the widest opening at the entrance of the collimator jaws to 23.5mm, only 3.5mm larger than the incoming beam pipe diameter. This may be useful in reducing further the possibility of disruptive “cavity modes” occurring due to the diverging/converging section between the entrance flare and the collimator jaws.

If the maximum collimator aperture could be reduced from the assumed 20mm full gap to 16.5mm, an extension of this option would be to dispense with the diverging flared section altogether, at least in the collimating plane.

Option 3: Constant Converging Taper

In this, the tapered sections leading to the Ti spoiler are replaced by flexible pieces alone. This has advantages in that RF cavity-like modes are unlikely, and the overall collimator length is a simple parameter of the taper angle that

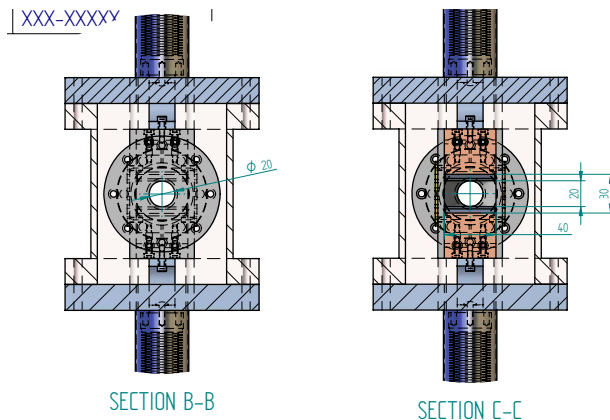

Figure 4: Along beam elevations: (Section B-B) at circular entrance to flared transition, and (Section C-C) at rectangular exit from flared transition; see also Figure 3.

can be tolerated by beam dynamics considerations, but has a taper angle which increases as the aperture of the collimators is reduced. There are also concerns about radiation load which could be tolerated by the flexible pieces.

Option 4: Wide Aperture

The final option increases significantly the non-collimating transverse dimension of the jaws, from a full width of 40mm to 120mm, if such were beneficial from considerations of RF design.

OUTPUT

The preliminary designs in their current stages of development are made available to collaborators [6].

CONCLUSIONS

A preliminary, conceptual design for the adjustable jaw spoilers for the ILC BDS is presented, to serve as a starting point towards a complete engineering design which can be achieved when design of the jaws themselves has been finalised. Generic features of this design can be extended to other collimators in the ILC BDS.

REFERENCES

- [1] A.M. Toader et al., these proceedings, abstract WEPP167.
- [2] J-L. Fernandez-Hernando et al., these proceedings, abstract WEPP163.
- [3] G.E. Ellwood et al., these proceedings, abstract WEPP162.
- [4] “International Linear Collider Reference Design Report, Volume 3. Accelerator”. ILC-REPORT-2007-001, <http://ilcdoc.linearcollider.org>
- [5] J.D.A. Smith, these proceedings, abstract WEPP165.
- [6] <https://twiki.cern.ch/twiki/bin/view/ILCBDSColl>